



Revista Mexicana de Física

ISSN: 0035-001X

[rmf@ciencias.unam.mx](mailto:rmf@ciencias.unam.mx)

Sociedad Mexicana de Física A.C.

México

Chávez, E.; Huerta, A.; Ortiz, M.E.; Rodríguez, P.; Favela, F.; Marín, D.; Moreno, E.; Murillo, G.;  
Policroniades, R.; Varela, A.; Barrón-Palos, L.  
Neutron elastic scattering on lead at 3.0 MeV  
Revista Mexicana de Física, vol. 53, núm. 6, -diciembre, 2007, pp. 13-16  
Sociedad Mexicana de Física A.C.  
Distrito Federal, México

Available in: <http://www.redalyc.org/articulo.oa?id=57028300003>

- How to cite
- Complete issue
- More information about this article
- Journal's homepage in [redalyc.org](http://redalyc.org)

[redalyc.org](http://redalyc.org)

Scientific Information System

Network of Scientific Journals from Latin America, the Caribbean, Spain and Portugal

Non-profit academic project, developed under the open access initiative

# Neutron elastic scattering on lead at 3.0 MeV

E. Chávez, A. Huerta, M.E. Ortiz, P. Rodríguez, F. Favela, and D. Marín  
*Instituto de Física, Universidad Nacional Autónoma de México,  
 México D.F. 04510.*

E. Moreno, G. Murillo, R. Policroniades, and A. Varela  
*Laboratorio del Acelerador, ININ,  
 Apartado Postal 18-1027, México D.F., México.*

L. Barrón-Palos  
*Arizona State University, P.O. Box 871504 Tempe, AZ 85287-1504.*

Recibido el 23 de febrero de 2007; aceptado el 5 de junio de 2007

Recent interest on precise information of the elastic scattering of fast (MeV) neutrons on  $^{208}\text{Pb}$  revealed the lack of sufficient experimental information. In this work we present new data obtained at the EN-Tandem Accelerator Laboratory of the “Instituto Nacional de Investigaciones Nucleares” (ININ). A tagged mono-energetic flux of neutrons is generated through the  $\text{D}(\text{d},\text{n})^3\text{He}$  reaction by detecting and identifying the conjugated Helium particles. The neutron “cone” produced this way is directed towards a  $^{nat}\text{Pb}$  target. The angular distribution of the scattered neutrons is measured between five and twenty degrees relative to the neutron direction by an array of plastic scintillators. Comparison with the previous data and optical model calculations is presented. Future perspectives are discussed.

*Keywords:* Nuclear reactions; neutron elastic scattering; angular distributions.

El reciente interés en la dispersión elástica de neutrones en  $^{208}\text{Pb}$  a ángulos pequeños reveló la falta de datos experimentales. En este trabajo presentamos nuevos datos obtenidos en el Laboratorio del Acelerador del Instituto Nacional de Investigaciones Nucleares (ININ) para la dispersión elástica de neutrones en  $^{nat}\text{Pb}$ . La distribución angular de los neutrones dispersados se midió entre 5 y 20 grados relativo a la dirección original del cono de neutrones mono energéticos (3 MeV) producidos por la reacción  $\text{D}(\text{d},\text{n})^3\text{He}$ . Estos datos se comparan con cálculos de modelo óptico así como con medidas anteriores. Finalmente se discuten las perspectivas a futuro para este tipo de medidas.

*Descriptores:* Reacciones Nucleares; dispersión elástica de neutrones; distribuciones angulares.

PACS: 25.40.Dn; 28.20.Cz; 28.41.Rc; 29.25.Dz; 04.50.+h

## 1. Introduction

This work is motivated by recent interest in the elastic scattering of fast neutrons. A. Frank *et al.* [1] showed that very precise measurements of the angular distributions of elastic scattering of neutrons on zero spin heavy targets (like  $^{208}\text{Pb}$ ) at small angles ( $< 20^\circ$ ) and energies around 1 MeV could provide evidence for the presence of anomalous gravity effects.

The use of neutrons as a probe to study properties of nuclei goes back to the earliest times of nuclear physics [2]. Six decades latter, the interest of using neutrons for nuclear studies is still growing. Laboratories around the world continue to develop facilities to make measurements every time more sophisticated and precise (see for instances [3-9]). A non exhaustive list of laboratories with current activity in neutron physics is presented in Appendix A.

In Mexico, at the Tandem Accelerator Laboratory of the Instituto Nacional de Investigaciones Nucleares (ININ), mono-energetic neutron fluxes are produced through the associated particle technique [10] with the  $^2\text{H}(^2\text{H},\text{n})^3\text{He}$  reaction [11-14]. The total neutron production achieved with this reaction is of the order of  $10^{11}$  n/s/mA which is not a very intense neutron source, but a useful and practical one. The desired neutron energy can be selected in the energy interval from 1.6 through 7 MeV with intensities of a few hundred

neutrons per second (see below). With this mono-energetic neutron flux, measurements of the elastic scattering of neutrons on different targets can be carried out. Neutron detectors were built by the ININ-IFUNAM collaboration using plastic scintillating material (BC-416) with large ( $\sim 75\%$ ) detection efficiency [13].

Previous data on elastic scattering of neutrons on  $^{208}\text{Pb}$  at incident energies of a few MeV can be found in [15,16]. The angular distributions presented in those papers show no measurements below  $15^\circ$ .

The theoretical framework to treat and understand the elastic scattering process is the optical model. A very large number of relevant works have been made, from the original fits of angular distributions at a single energy and for specific systems, to the recent efforts made to find potential parameterizations that can explain large number of data and produce systematic sets of parameters that can be extrapolated in energy and mass of the target [17-30]. The lack of elastic scattering data at small angles is a source of uncertainties in the determination of the optical model potential.

In Sec. 2, the experimental setup used in the present work is described. In Sec. 3, the results of our measurements are presented together with predictions from different optical model calculations. Conclusions can be found in Sec. 4.

## 2. Experimental procedure

The main features of the experimental procedure to produce a mono-energetic neutron flux (“beams”) at ININ’s facilities have been described in previous publications [13,14]. The specific setup for the present measurement is schematically shown in Fig. 1.

Deuteron beams (3.7 MeV, 50 to 200 nA) from ININ’s Tandem accelerator were delivered to a reaction chamber on a “deuterated” polyethylene (CD<sub>2</sub>) film, 200 μg/cm<sup>2</sup> (0.002 mm) thick target, mounted on a rotating frame placed eccentric to the direction of the incident beam, to allow cooling of the target and avoid damage. Nearly 99% of the hydrogen atoms in the film are substituted by deuterium (<sup>2</sup>H). <sup>3</sup>He ions produced by the <sup>2</sup>H(<sup>2</sup>H,n)<sup>3</sup>He reaction were detected in a well collimated solid state detector inside the reaction chamber at a given angle. In our experiment we detected up to 150 <sup>3</sup>He ions per second at 30 deg with a tight collimation down to 0.83 msr. The coincident (or associated) neutrons produced have a well defined energy which is controlled by beam energy and <sup>3</sup>He detection angle. These neutrons form an approximately conic flux. The opening angle of this cone depends on the size of the collimator of the <sup>3</sup>He detector, and it has to be measured. In our experiment this (total) opening was of 4 deg. These true mono-energetic neutron “beams” produced at ININ’s facility have intensities (fluencies) that are comparable to those attained in any other laboratory in the world.

Once the direction and profile of the neutron flux is determined, a cylindrical block (26.7 mm diameter and 28 mm high) of <sup>nat</sup>Pb (8.92x10<sup>22</sup> atoms/cm<sup>2</sup>) is placed as a secondary target right outside the reaction chamber, 150 mm away from the CD<sub>2</sub> primary target. The dimension of our lead target was chosen to be wide enough to encompass the whole neutron beam and thick enough to allow nearly 50% transmission, which is a good compromise to balance the

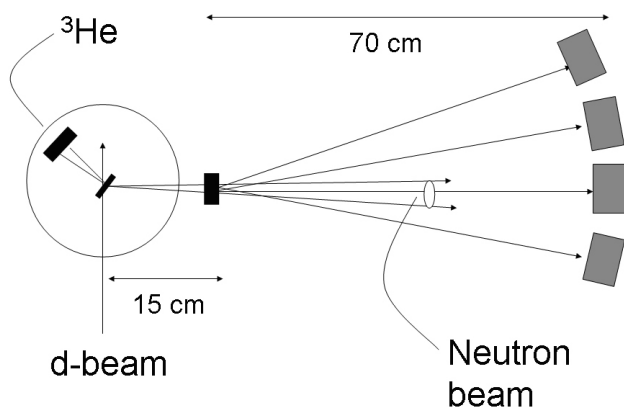

FIGURE 1. Schematic view of the experimental array. The deuteron beam from ININ’s tandem accelerator enters the reaction chamber and hits a rotating deuterated polyethylene target. <sup>3</sup>He ions are detected inside the vacuum chamber and coincident neutrons are directed towards the Lead secondary target outside the chamber. Scattered neutrons are detected by a detector array.

probability of neutron single and multiple scattering in the target.

A table was built to rotate around the center of the secondary lead target and to support the neutron detectors in a plane that contains the <sup>3</sup>He detector inside the chamber and the lead target itself. On this table, four cylindrical (50 mm diameter by 76 mm long) NE-102A plastic scintillating detectors were placed 5 deg apart from each other at a constant distance (700 mm) from the secondary target. At this distance, their full angular acceptance was 4.1 deg each. Four different settings were used on data taking runs by rotating the table, corresponding to detector #1 at 0, -2, -3 and -4 deg and the rest of the detectors placed sequentially counterclockwise, 5 deg apart from each other (laboratory angles).

Electronic fast time signals were constructed from every pulse of the neutron detectors (photo multipliers) as well as from the solid state <sup>3</sup>He detector and sent to our CAMAC acquisition system into a time to digital converter (TDC) which was electronically triggered by the <sup>3</sup>He positively identified signal (<sup>3</sup>He is identified by energy in a single channel analyzer). The host computer (PC) stores the energy spectrum from the solid state detector (<sup>3</sup>He) and the time differences between that and the neutron detectors in an event by event mode for off line analysis. A total of 4x10<sup>6</sup> <sup>3</sup>He ions were detected throughout our experiment (and also that many neutrons produced in our mono-energetic flux).

Figure 2 shows a typical time of flight spectrum in logarithmic scale. The large peak corresponds to the true <sup>3</sup>He-n coincidences. As can be seen it is several orders of magnitude larger than the smooth background from random coincidences. The second, smaller peak to the right in the spectrum might be identified with the inelastic scattering to the first excited state of <sup>208</sup>Pb.

The elastic scattering data from neutron detectors placed within (fully or partially) the “neutron cone” contains an important contribution from the transmitted, non scattered, neutrons. Because of the limited statistics of our experiment, the elastic scattering data taken at angles below 5 deg could not be reliably disentangled from the transmitted neutron flux.

## 3. Results and discussion

The present experiment is the first of a series whose ultimate goal is to measure the angular distribution of the elastic scattering of neutrons on <sup>208</sup>Pb as precisely as possible.

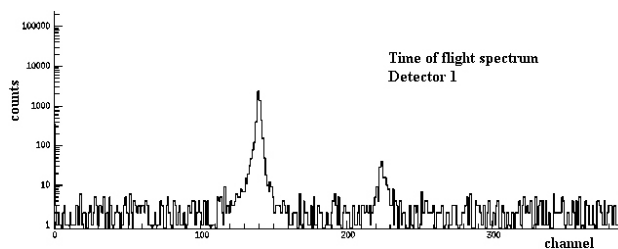

FIGURE 2. Typical time of flight spectrum taken at 5 degrees, where the large peak corresponds to the true <sup>3</sup>He-n coincidences.

In this report, besides presenting new data on the system under study, we draw significant conclusions about the future evolution of our program.

In Fig. 3, we show the result for the angular distribution at small angles from optical model calculations made with the code SNOOPY [31] (other codes like Cupid [32] and Ptolemy [33] yield similar results), by using the more recent sets of optical parameters [30]. In these calculations, the angular distribution predicted for the elastic scattering of 3.0 MeV neutrons on lead isotopes 204, 206 and 207 are presented. The mass of the isotopes are taken into account in the systematics, through the calculation of their radius. The observed differences are of the order of a few percent, which for some applications can be neglected considering that in neutron experiments one deals with a variety of important sources of uncertainty, but should be kept in mind when precision measurements are sought.

Figure 4 shows our measurement of the angular distribution. The horizontal error bars reflect the size of our detectors and the width of the mono-energetic neutron flux. The vertical error bars is only the statistical error. Lines joining our data points have no other purpose than to guide the eye. For convenience, the angles are given in the laboratory reference system (as well as for the accompanying calculations).

Together with our data four smooth curves are plotted. Those are the result of optical model calculations with different sets of parameters. These calculations include those of Perey and Perey published in 1976 [29], giving a compilation of parameters for the potential that is still used today. In that compilation two families of potentials are quoted to fit elastic scattering of neutrons on lead, one of them including a spin-orbit term. More recently Rapaport *et al.* [28] proposed

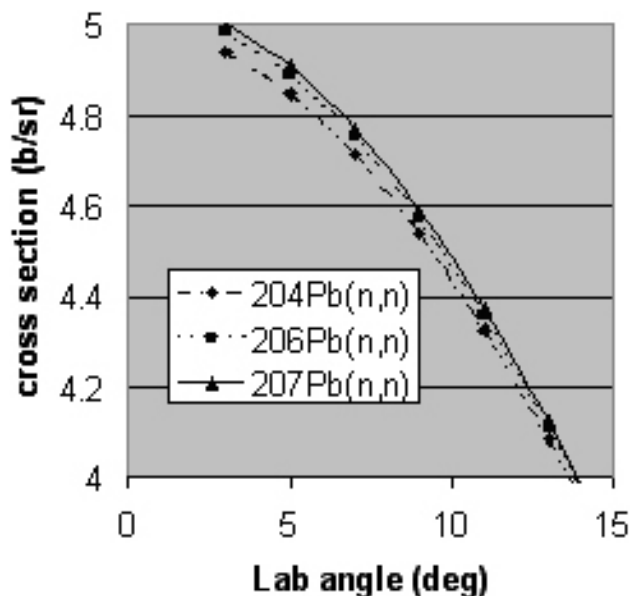

FIGURE 3. Mass dependence of the elastic scattering of neutrons on different isotopes of lead at the same neutron energy, in agreement to Optical Model systematics by Koning and Delaroche [30].

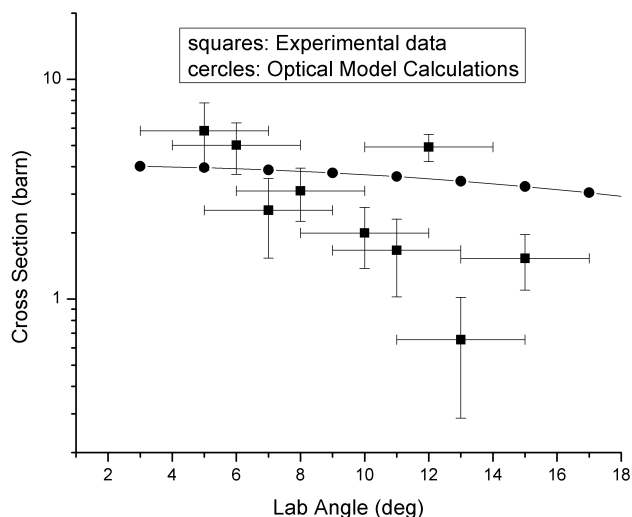

FIGURE 4. Angular distributions for neutron elastic scattering on lead at small angles (preliminary analysis). Result of predictions from Optical Model calculations using different prescriptions for the potential are presented together with our measurements.

systematic way of finding parameters for the optical model potential for arbitrary systems and finally Koning and Delaroche [30] produced the latest review on the subject and provided their own proposal for the potentials.

#### 4. Conclusions

We present here the first measurement of an angular distribution of the elastic scattering of neutrons on  $^{nat}\text{Pb}$  in the angular interval of 5 to 15 deg.

We show that a valuable application of the mono-energetic neutron fluxes from ININ's laboratory is to perform precise studies of nuclear properties. It would be desirable to increase the intensity of the neutron "beams" by as much as possible without losing its mono-energetic quality. Solid thin targets can not withstand large charged particle beam's intensities. A windowless supersonic gas jet target is under design by our group to substitute the polyethylene one. A faster and more robust detector is needed to detect and identify the  $^3\text{He}$  ions, gas chambers and plastic scintillators are good options.

The relatively low number of neutrons produced stresses the importance of detecting the larger possible fraction of them, whether transmitted through the secondary target or scattered. Larger solid angle coverage for the neutron detectors becomes a priority. Our group is building more neutron detectors as well as designing and constructing a large two dimensional position sensitive neutron detector to increase the solid angle coverage at small angles by two orders of magnitude.

Because of the fraction of the neutron "beam" transmitted through the lead target, a precise determination of the angular distribution of the elastic scattering of neutrons in any target, at angles comparable or smaller than the angular opening of the neutron cone, is unrealistic.

The determination of the angular distribution of the elastic scattering of neutrons on lead with high precision will help determine the characteristics of the optical model potential that best explains the observations. As of now, theory predictions disagree with each other by as much as 10% at low angles.

When the experimental data reaches its precision limit and theory converges, only then, it will be possible to answer the question raised by A. Frank *et al* [1] about possible non standard gravitation, and additional dimensions of the universe.

## A Appendix

Laboratories with current activities in neutron physics (partial list):

### North America:

- o Spallation Neutron Source, Oak Ridge
- o Intense Pulsed Neutron Source, Argonne
- o Los Alamos Neutron Science Center (LANSCE)
- o University of Missouri Research Reactor Center
- o High Flux Isotope Reactor, Oak Ridge
- o Ohio University Beam Swinger Neutron Spectrometer

o Neutron Program for Materials Research, Chalk River, Canada

### Europe:

- o ISIS-Rutherford-Appleton Laboratories, United Kingdom
- o TOF-facility at CERN
- o Institut Laue-Langevin, Grenoble, France
- o Leon Brillouin Laboratory, Saclay, France
- o Hahn-Meitner Institute, Berlin, Germany
- o GKSS Geesthacht, Germany
- o Neutron Scattering Group, FZ- Juelich, Germany
- o FRM-II, Munich, Germany
- o KFKI, Hungary
- o IRI, Delft, The Netherlands
- o Studsvik Neutron Research Laboratory, Sweden
- o SINQ, Paul Scherrer Institut (PSI), Switzerland
- o Frank Laboratory of Neutron Physics, Dubna, Russia
- o St. Petersburg Neutron Physics Institute, Gatchina, Russia

### Asia and Australia:

- o ISSP Neutron Scattering Laboratory, Tokai, Japan
- o JAERI Research Reactors, JAERI, Tokai, Japan
- o KENS Neutron Scattering Facility, Tsukuba, Japan
- o Hi-Flux Advanced Neutron Application Reactor, Korea
- o Bragg Institute, ANSTO, Australia

- 
1. A. Frank, P. Van Isacker, J. Gómez-Camacho, *Phys Lett B* **582** (2004) 15.
  2. J.B. Marion and J.L. Fowler, *Fast neutron physics* (Interscience Publishers, New York-London 1963).
  3. L. Disdier, J-P. Garconnet, G. Malka and J-L. Mique, *Phys. Rev. Lett.* **82-7** (1999) 15.
  4. J. Klug *et al.*, *Nucl. Inst. Meth. A* **489** (2002) 282.
  5. U. Tippawan *et al.*, The n-TOF Collaboration, *Phys. Rev. C* **69** (2004) 064609.
  6. U. Abbondanno *et al.*, *Nucl. Phys. A* **758** (2005)501.
  7. P. Schleger *et al.*, *Physica B* **241** (1998) 164.
  8. P. Schleger *et al.*, *Physica B* **266** (1999) 49; A.I. Frank, I.V. Bondarenko, A.V. Kozlov, P. High, and G. Ehlers, *Physica B* **297** (2001) 307.
  9. R. Cherubini, G. Moschini, R. Nino, R. Policroniades and A. Varela, *Nucl. Instr. and Meth. A* **269** (1988) 623.
  10. E. Chávez L. *et al.*, *Mex. Nucl.* **3** (2002) 9.
  11. A. Varela *et al.*, *Mex. Nucl.* **5** (2004) 35.
  12. R. Monroy *et al.*, *Proceedings Int. Conf., AIP* **726** (2004) 237.
  13. R. Policroniades *et al.*, *Rev. Mex. Fís. S* **53(3)** (2007) 74.
  14. J.L. Fowler and E.C. Campbell, *Phys Rev* **127** (1962) 2192.
  15. J.R.M. Annand, R.W. Finlay, and F.S. Dietrich, *Nucl. Phys. A* **443** (1985) 249.
  16. L.F. Hansen, F.S. Dietrich, B.A. Poho, C.H. Poppe and C. Wong, *Phys Rev C* **31** (1985) 111.
  17. S. Karataglidis and M. B. Chadwick, *Phys. Rev. C* **64** (2001) 064601.
  18. P.K. Deb, K. Amos, S. Karataglidis, M.B. Chadwick and D.G. Madland, *Phys Rev Lett* **86** (2001) 3248.
  19. S. Karataglidis, K. Amos, B.A. Brown, and P.K. Deb, *Phys. Rev. C* **65** (2002) 044306.
  20. A. Molina, R. Capote, J.M. Quesada, and M. Lozano, *Phys. Rev. C* **65** (2002) 034616.
  21. R.S. Caswell, *J. Res. Nat. B. Std.* **66A-5** (1962) 389.
  22. R.E. Shamu, S.M. Ferguson, and R.L. Schutt, *J. Phys. G* **25** (1999) L125.
  23. M. Bender, P.-H. Heenen, P.-G. Reinhard, *Rev Mod Phys* **75** (2003) 121.
  24. T.P. Stuart, J.D. Anderson, and C. Wong, *Phys. Rev.* **125** (1962) 1.
  25. J. Klug, *Elastic Neutron Scattering at 96 MeV*, Acta Universitatis Upsaliensis, (Comprehensive Summaries of Uppsala Dissertations from the Faculty of Science and Technology 854 2003). vi+50 pp, Uppsala. ISBN 91-554-5663-4.
  26. C.D. Roper, *Phys Rev C* **72** (2005) 024605.
  27. J. Rapaport, V. Kulkarni, and R.W. Finlay, *Nucl. Phys. A* **330** (1979) 15.
  28. C.M. Perey and F.G. Perey, *Atomic Data and Nucl. Data Tabl.* **17** (1976) 1
  29. A.J. Koning and J.P. Delaroche, *Nucl Phys A* **713** (2003) 231.
  30. P. Schuant, *Code SNOOPY8Q*, (Indiana University 1986), Report IUCF No. 85-9/471.
  31. J.R. Comfort, *Search code CUPID* Univ. of Pittsburgh (unpublished)
  32. S. Pieper, M.H. Macfarlane and M. Rhoades-Brown, *Code PTOLEMY* (Argonne National Laboratory 1976) Report ANL-76-11.