



TecnoLógicas
ISSN: 0123-7799
ISSN: 2256-5337
tecnologicas@itm.edu.co
Instituto Tecnológico Metropolitano
Colombia

Qualitative and Quantitative Evaluation of Overcurrent Protection in Active Distribution Systems

Grisales-Soto, Brayner; Pérez-Londoño, Sandra; Mora-Flórez, Juan
Qualitative and Quantitative Evaluation of Overcurrent Protection in Active Distribution Systems
TecnoLógicas, vol. 25, núm. 55, e2353, 2022
Instituto Tecnológico Metropolitano, Colombia
Disponible en: <https://www.redalyc.org/articulo.oa?id=344272383004>
DOI: <https://doi.org/10.22430/22565337.2353>



Esta obra está bajo una Licencia Creative Commons Atribución-NoComercial-CompartirIgual 4.0 Internacional.



Qualitative and Quantitative Evaluation of Overcurrent Protection in Active Distribution Systems

Evaluación cualitativa y cuantitativa de la protección de sobrecorriente en sistemas de distribución activos

Brayner Grisales-Soto
Universidad Tecnológica de Pereira, Colombia
 brainer010@utp.edu.co

 <https://orcid.org/0000-0003-4053-7569>

DOI: <https://doi.org/10.22430/22565337.2353>

Redalyc: <https://www.redalyc.org/articulo.oa?id=344272383004>

Sandra Pérez-Londoño
Universidad Tecnológica de Pereira, Colombia
 saperez@utp.edu.co

 <https://orcid.org/0000-0002-1766-4618>

Juan Mora-Flórez
Universidad Tecnológica de Pereira, Colombia
 jjmora@utp.edu.co

 <https://orcid.org/0000-0002-3415-5065>

Recepción: 18 Marzo 2022
 Aprobación: 22 Agosto 2022

ABSTRACT:

Greenhouse gas emissions are considered a global problem, which is why interest in implementing renewable distributed energy resources (DER) is increasing worldwide. However, despite the contributions to the reduction of fossil primary energy sources, the connection of DERs to power grids often gives rise to new problems in control, operation and protection systems that need to be analyzed and solved. The objective of this paper was to compare a conventional overcurrent protection scheme and several adaptive schemes for active distribution networks (ADN). The proposed methodology consisted of performing an analysis of the adaptive protection approaches for ADN. From this evaluation, the most relevant documents were classified according to the main requirements, contributions, and conclusions. Additionally, some of these proposals were tested with conventional overcurrent protection, using the ATP simulator and Python software. Finally, a quantitative and qualitative analysis of the proposed protection approaches was performed in order to identify limitations to be considered in future research work. The results obtained, when considering different faults and modes of operation of the DNA, showed that the conventional protection coordination approach is highly vulnerable to faults when DERs are connected, mainly due to the change in current magnitudes and direction. The adaptive schemes analyzed have adequate performance, however, several application issues need to be analyzed in the future.

KEYWORDS: Coordination time interval, adaptive protection, overcurrent protection, distributed.

RESUMEN:

Las emisiones de gases de efecto invernadero se consideran un problema global, razón por la cual el interés por implementar recursos energéticos distribuidos renovables (DER, por sus siglas en inglés) experimenta un incremento mundial. Sin embargo, a pesar de las contribuciones a la reducción de las fuentes de energía primaria fósiles, la conexión de los DER a las redes eléctricas suele originar nuevos problemas en los sistemas de control, operación y protección que deben ser analizados y resueltos. El objetivo de este artículo fue comparar un esquema de protección de sobrecorriente convencional y varios esquemas adaptativos para redes de distribución activas (ADN, por sus siglas en inglés). La metodología propuesta consistió en realizar un análisis de los enfoques de protección adaptativa para ADN. A partir de esta evaluación, se clasificaron los documentos más relevantes según los principales requisitos, aportes y conclusiones. Adicionalmente, se probaron algunas de estas propuestas con la protección de sobrecorriente convencional, utilizando el simulador ATP y el software Python. Por último, se realizó un análisis cuantitativo y cualitativo de los enfoques de protección propuestos con el fin de identificar limitaciones que deben considerarse en futuros trabajos de investigación. Los resultados obtenidos, al considerar diferentes fallas y modos de operación del ADN, demostraron que el enfoque de coordinación

de protección convencional es altamente vulnerable a fallas cuando los DER están conectados, principalmente por el cambio en las magnitudes y dirección de las corrientes. Los esquemas adaptativos analizados tienen un desempeño adecuado, sin embargo, varios problemas de aplicación deben ser analizadas a futuro.

PALABRAS CLAVE: Intervalo de tiempo de coordinación, protección adaptativa, protección de sobrecorriente, recursos energéticos distribuidos, redes de distribución activas.

HIGHLIGHTS

- Conventional overcurrent protection has significant drawbacks in ADNs
- The main challenges and limitations of actual adaptive protection in ADNs are reviewed
- Adaptive overcurrent protection can be a solution for ADNs protection
- The essential aspects required by adaptive protection approaches are presented

1. INTRODUCTION

As a consequence of energy demand and the requirement to reduce CO₂ emissions, the penetration of distributed energy resources (DER) such as photovoltaic (PV), wind turbines, fuel cells, and microturbines constitutes a potential solution to mitigate climate change [1]. Besides, technological improvements have led to the integrating of these sources into the system, making a leap from radial distribution systems to the active distribution network (ADN), which contains multiple generation and storage systems [2]. However, this process has resulted in a considerable change in the power flow and short-circuits capability of the distribution system, making it difficult to control, operate, and protect [3], [4]. Therefore, this paper analyzes some of the protection approaches proposed to surpass the ADN issues.

Traditional overcurrent protection cannot accurately determine the fault condition in ADN, then the protection system malfunctions, as shown in [5], where the authors evidence several problems. Authors in [6] review the main challenges and benefits of DER integration into the network. In addition, the authors show an overview of some solutions to these challenges and how these can be addressed in Colombia, especially in non-interconnected zones (NIZ). Therefore, to ensure the safe and stable operation of the distribution system, it is of great importance to implement protection systems that adapt to system changes, as presented in [7], which reviews and classifies the protection strategies proposed to mitigate the impacts of DERs in electric distribution systems. In [8], a critical review of problems and challenges resulting from the DERs penetration is presented, where a qualitative analysis of adaptive protection schemes is performed, highlighting each proposal's methodology, limitations, and conclusions. Similarly, in [9], a review of the adaptive protection approach for ADN is presented, where each approach's drawbacks and advantages are analyzed, highlighting the main gaps to be addressed.

Adaptive protection is a possible solution to ADN issues, as described in [10]. Among the solutions, the first group of proposals continuously monitors the system's state and uses this information to determine changes in the relay configuration to adapt their parameters to the different ADN operating conditions. Some adaptive approaches, such as [11] and [12], study several changes and ADN configurations, where the study and coordination of protections are performed offline. Once this information is stored, an operating control center (OCC) monitors the system's state and sends new settings to the relays. In [13], an adaptive algorithm for coordinating overcurrent protection is proposed; in the case of ADN changes, a power flow calculation is performed by an OCC to coordinate and update the relays.

Similarly, in [14], several OCCs are used to group a certain number of relays; online, each OCC monitors the status of the circuit breakers and the voltage and current measurements in its area. A micro-genetic-based algorithm recalculates and updates the relay settings when there are changes in the network. The authors in [15] propose an adaptive protection scheme divided into an offline and an online stage, where the optimal

setting groups (SGs) for some operation modes are obtained using the symbiotic organism search (SOS) algorithm in the first stage. In the second stage, an OCC monitors the state of the network and runs the SOS algorithm to obtain new SGs if required.

In the same way, in [16]-[19], use intelligent electronic devices and a communication system to obtain real-time information. This data is stored in the OCC when an optimal coordination calculation is performed, and the new configuration parameters are defined and sent to the relays. In [20], a decentralized adaptive coordination approach divided into two stages is presented. The first stage consists of clearing a fault in a conventional approach; when it is not possible, a second stage forms a group of agents. These are in charge of negotiating the best coordination strategy based on the probabilities of a correct operation. However, a communication protocol between agents is necessary, and clearing a fault in the second stage can take a long time.

The second group does not use a communication infrastructure [21]-[24]. The approaches [21] and [22] are mainly focused on data mining and signal processing. Therefore, characteristics and indices are formulated to determine, identify, and classify faults and different system operating modes using classifiers. An optimal coordination approach for dual configuration overcurrent relays is proposed in [23]. Different optimization techniques are used in this approach to find a single relay setting to operate in the grid-connected and islanded mode. In [25], an adaptive protection coordination approach that does not require relay resetting is proposed. In this strategy, through an iterative and offline process, the optimal penetration level of the DERs is obtained, considering constraints such as minimum power losses and voltage limits. However, only PV resources are considered. In [26], an adaptive protection strategy using Machine Learning techniques is used. Intelligent electronic devices (IEDs) use a database obtained offline and, by taking local current and voltage measurements, discriminate between a normal and a fault state. However, the IED has a high computational burden. In [27], an adaptive protection scheme is proposed where the relays' operating times are initially calculated for a base operating mode. Subsequently, the sensitivity index is calculated by relating the time difference between a new operating and the base modes. Finally, the optimal relay settings are obtained using an objective function that minimizes the sensitivity index and the number of operating modes. However, this approach may be limited to specific operating modes. Other approaches, such as [28], are based on performing an equivalent ADN transformation back to the location of the relay, considering local online measurements to obtain the settings of the relay.

Conventional overcurrent protection schemes do not perform adequately in ADN, losing coordination or not detecting the fault once the system changes this operation mode. This paper presents a classification of the adaptive protection proposals as a part of the solution. The implementation of the selected proposals presents a qualitative and quantitative analysis to determine the gaps and the improvement opportunities of the conventional and adaptive protection approaches to be considered in future work, considering different ADN operating modes. Additionally, some aspects required in a robust protection scheme are evaluated. The selected and compared adaptive protection schemes are proposed in [17]-[19], [28].

The proposed methodology is divided into three stages. In the first stage, the search, selection, and classification of related papers obtained from specialized databases are performed. Thus, a review of proposals for adaptive protection for ADNs in databases such as IEEEXplore, ScienceDirect, Springer, and IET, among others, is carried out. Then, the most relevant documents are classified according to the main requirements, contributions, and conclusions.

The best-classified papers are analyzed in the second stage to determine the selected proposals. This determination considers the implementation feasibility and efficiency of the analyzed algorithm, which is also compared in quantitative analysis.

Finally, in the last stage, the selected adaptive protection schemes, along with the conventional protection scheme, are coded using Python software. The approaches are evaluated in a test system, and a quantitative comparison is performed.

2. METHODOLOGY

The proposed methodology is divided into three stages. In the first stage, the search, selection, and classification of related papers obtained from specialized databases are performed. Thus, a review of proposals for adaptive protection for ADNs in databases such as IEEEExplore, ScienceDirect, Springer, and IET, among others, is carried out. Then, the most relevant documents are classified according to the main requirements, contributions, and conclusions.

The best-classified papers are analyzed in the second stage to determine the selected proposals. This determination considers the implementation feasibility and efficiency of the analyzed algorithm, which is also compared in quantitative analysis.

Finally, in the last stage, the selected adaptive protection schemes, along with the conventional protection scheme, are coded using Python software. The approaches are evaluated in a test system, and a quantitative comparison is performed.

2.1 Description of relevant strategies for adjusting overcurrent protection relays

Traditionally, protective relay coordination can be achieved using the ADN topology, optimization methods, or even learning-based approaches [29], [30]. In a power system, each protective relay has to clear faults in its specific zone (primary protection) and a secondary function to clear faults in the adjacent or downstream zones of influence (backup protection). In the case of a fault, the protective device's cleared area must be as small as possible; only the primary protection must operate (the device nearest to the fault location). When the device closest to the fault does not operate, the following upstream devices must operate to provide backup protection. The coordination procedure assured the satisfactory operation of primary and backup protection [31].

2.1.1 Conventional approach for overcurrent relay coordination

Several parameters define overcurrent relays as the pickup current (I_p), the curve type, and the time dial setting (TDS). The operation time (t) is defined by (1) according to the IEC 255 standard [32], A and P are constants to define the inversion degree, and M is defined by (2), where I_F is the fault current.

$$t = \frac{A}{M^P - 1} TDS \quad (1)$$

$$M = \frac{I_F}{I_p} \quad (2)$$

Two three-phase bolted faults are required for phase relay coordination. The first is near the relay (local maximum fault), while the second is at the end of the protected line (maximum remote fault). The local maximum fault is used to calculate the local operation time (t_L), and the maximum remote fault is used to determine the remote operation time (t_R).

In the system shown in Figure 1, the coordination procedure is frequently initiated at the farthest node from the source. Equation (1) is used to calculate the t_L of the relay $n-1$. Besides, the coordination equation

defined by (3) is used to calculate the t_R of relay n , where the coordinating time interval (CTI) refers to the time required for the breaker to open the fault and an additional time as a safety criterion.

$$t_{R_n} \geq t_{L_{n-1}} + CTI_{52_{n-1}} \quad (3)$$

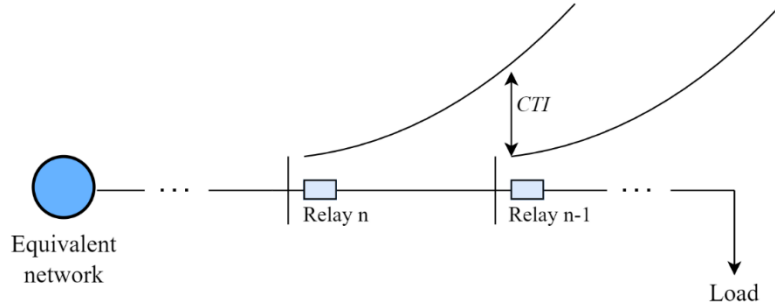

FIGURE 1.
Adequately coordinated 51 relays
Source: Created by the authors.

The t_{R_n} , maximum remote fault I_F , and I_p of relay n are used to calculate the minimum time dial setting (TDS_n) (4). The local maximum I_F and I_p are used to calculate the t_{L_n} using (1).

$$TDS = \frac{t_{R_n}(M^P - 1)}{A} \quad (4)$$

The previous process is repeated up to the relay closest to the source (N). The equation defined by (5) must be satisfied for this relay. In addition, the time defined for the coordination of the equivalent system must be greater than or equal to $t_L + CTI$.

$$t_{network} \geq t_{L_N} + CTI_{52_N} \quad (5)$$

2.1.2 Sequence currents-based adaptive protection approach for DNs with DER (Adaptive Approach I)

The paper presented in [17], proposes an adaptive directional overcurrent relay approach based on sequence currents for ADN. The relay settings obtained for the grid-connected mode would not guarantee the relay coordination for the other operating modes of the analyzed system. Depending on the operating mode change, the authors propose the calculation of an adaptive TDS defined by (6).

$$TDS_{new} = \frac{(M)_{new}^P - 1}{(M)_{old}^P - 1} TDS_{old} \quad (6)$$

The relay calculates an adaptive TDS when a fault has occurred. Each relay stores the pre-fault positive sequence current, TDS , and I_F in the grid-connected mode. Using the value of pre-fault positive sequence current and I_F seen in the new operating mode, it adjusts the TDS value to maintain coordination.

Directional overcurrent relay (DOCR) based on negative sequence current is used as backup protection, and the DOCR based on positive sequence current is selected as the primary protection in the ADN. However, the positive sequence fault current is used as the operating quantity for the backup protection for balanced faults.

2.1.3 Superimposed Adaptive Sequence Current Based Microgrid Protection: A New Technique (Adaptive Approach II)

The authors in [18] propose calculating an impact factor (FI) based on the operation of the ADN. The use of the FI is oriented to maintain the fault current magnitude and, consequently, to assure relay coordination. FI is calculated depending on the types of resources connected to the distribution system. In the case of faults where the contribution of only inverter-based DERs is considered, the FI is calculated using (7). ΔI_{1F} is the superimposed positive-sequence fault current, I_{1F} is the positive-sequence fault current, and I_{1pre} is the pre-fault positive-sequence current. Otherwise, the FI is calculated using (8). All currents in (7) and (8) are in p.u.

$$FI = \frac{|\Delta I_{1F}|}{|1 - I_{1F}| |1 - \Delta I_{1F}| |I_{1pre}|} \quad (7)$$

$$FI = \frac{|\Delta I_{1F}| - |I_{1pre}|}{|\Delta I_{1F}|} \quad (8)$$

In addition, a new adaptive fault current (I_{Fad}) is defined by (9) and calculated at the relay location using the negative-sequence and positive-sequence fault currents and the FI .

$$I_{Fad} = (I_{1F} + I_{2F})(FI) \quad (9)$$

The adaptive fault current is used with the inverse definite minimum time (IDMT) curve as presented in (1) to calculate the tripping time [25]. Then, based on the operating mode of the ADN, the TDS of the relay is adjusted. The new TDS is calculated for each change in the ADN operation mode using the TDS value, fault, and pre-fault current from the previous mode of operation, as presented in (10).

$$TDS_{new} = \frac{(M)_{old}^p - 1}{(M)_{new}^p - 1} TDS_{old} \quad (10)$$

2.1.4 Dynamic adaptive protection for distribution systems in Grid-Connected and Island (Adaptive Approach III)

The approach in [19] presents an adaptive instantaneous overcurrent relay (50) for ADNs. As relays must guarantee reliable performance for load current and fault current capability changes, authors consider that these two aspects depend on the time of day, operating mode, and the DER state (on/off). Consequently, the paper focuses on estimating an adaptive pickup current (I_{Pad}) as proposed in (11).

$$I_{Pad} = aI_{mov_{10s}} + b(I_{FDERs} - aI_{mov_{10s}}) \quad (11)$$

The scheme adjusts the relay sensitivity using the locally measured load current's 10-second moving average window filter ($I_{mov_{10s}}$). Besides, it considers the maximum fault current supplied by the connected DERs (I_{FDERs}). When any DERs are offline, this fault contribution is not considered. Constant a provides a margin from the non-faulted line load, and b helps the relays maintain sensitivity. These are arbitrarily chosen constants such as $a \in [1.5, 2]$ and $b \in [0, 0.5]$. This protection scheme ensures coordination with backup protection.

2.1.5 An adaptive directional current protection scheme for distribution system with DG (Adaptive Approach IV)

An adaptive overcurrent protection scheme based on the fault steady-state component is proposed in [28]. After a fault occurs, the equivalent system at the backside of the protective relay is replaced by a Thevenin equivalent. In this case, an adaptive pickup current is online calculated according to the actual system operation mode, fault type, and local voltage and current measurements.

When a metallic three-phase fault occurs in the system, the measured voltage and current at the relaying point of the faulted line satisfy (12), where U_F and I_F are the measured voltage and current at the relaying point. Z_L is the impedance of the protected line, and α is the per unit length from the relay to the fault.

$$U_F = I_F \alpha Z_L \quad (12)$$

The setting value of the pickup current of the primary protection (I_{Pad}) in the case of a three-phase fault is defined by (13), where K_r is the reliability coefficient.

$$I_{Pad} = \left| \frac{K_r U_F}{Z_L} \right| \quad (13)$$

When the fault current measured (I_F) is bigger than I_{Pad} ; thus, the protection sends a trip to the corresponding circuit breaker.

2.2 Essential aspects in an adaptive protection approach

Table 1 shows some essential aspects evaluated in each adaptive protection approach presented above. Each aspect is described below:

- Consideration of different ADN operation modes, including connected and disconnected from the grid (Connected and islanded mode).
- Capability of the proposal to work adequately in radial and meshed systems (Radial and meshed).
- Consideration of inverter and synchronous based DERs (DER type).
- Requirement of communication systems (Communication scheme).
- Identification of the fault direction (Fault direction).
- Computation burden required in relay parameter estimation (Computation burden).
- Identification of the protective function (Protective function).

TABLE 1.
Comparison of ADN protection approaches

Aspects analyzed	References analyzed			
	Appro. I	Appro. II	Appro. III	Appro. IV
Connected and islanded mode	Yes	Yes	Yes	Yes
Radial and meshed	Not	Not	Not	Not
DERs type	Not	Yes	Yes	Yes
Communication schemes	Yes	Yes	Yes	Not
Fault direction	Yes	Yes	Not	Yes
Computation burden	Yes	Yes	Not	Yes
Protective function	51	51	50	50

Source: Created by the authors.

3. TESTS AND RESULTS

3.1 Test system

The software used to simulate the ADN is the ATP version of the Electromagnetic Transient Program (EMTP). The test system is a medium voltage (34.5 kV) distribution circuit, depicted in Figure 2. This system has a ring in the central part that connects nodes B, C, and D using three-phase lines. A 20 km length line connects nodes B-D, and nodes B-C, D-C, and C-G are connected with 10 km length lines. The macro-grid is connected to the system by a line with a 10 km length to node B. Similarly, a 10 km line connects the ring system at node D to node F, where PV-based DER (1 MVA) is located. A DFIG-based DER (3 MVA) is coupled by a 10 km length line in node C. Likewise, node G has battery-based energy storage (0.5 MVA). Finally, the system has three distributed loads at nodes F, C, and E, with 1 MVA, 2 MVA, and 1 MVA, respectively, and an inductive power factor of 0.95.

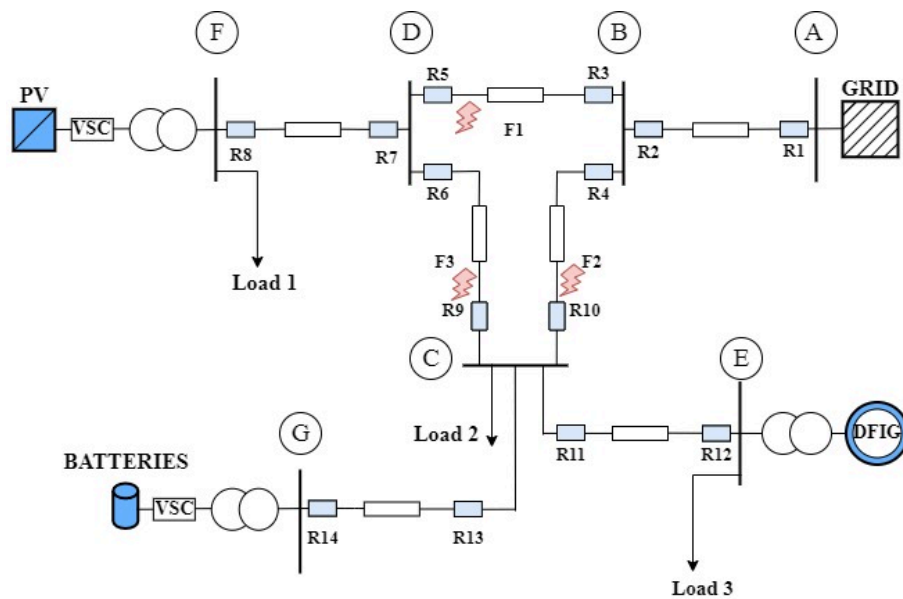

FIGURE 2.
Active distributed system used as a test system
Source: Created by the authors.

3.2 Testing scenarios

Three operation modes are proposed for the ADN, namely:

- Operation mode I (OM I): All sources are on this operation mode.
- Operation mode II (OM II): Only the DFIG-based DER is on in this operation mode. The remaining DERs are offline.
- Operation mode III (OM III): In this case, only the PV-based DER is on.

3.3 Test results

To compare the performance of the proposed approach concerning the reliability, selectivity, speed, and safety of each approach described in section II (adaptive and conventional), where three faults are simulated, as shown in Figure 2, for each operation mode described in the previous subsection. Thus, the conventional and the adaptive approaches I and II are evaluated using inverse definite minimum time relays. On the other hand, adaptive approaches III and IV are evaluated using instantaneous overcurrent relays.

Tables 2, 3, and 4 show the results obtained for each scenario. Three columns of data are shown for the conventional, adaptive approaches I and II. The first one corresponds to the TDS , the second is the relay operation time of each relay (t), and the third is the time difference (ΔT) between t_R of the backup protection and t_L of the primary protection. Besides, the primary relay is represented as R , and the backup relay as $/R$ for each fault. Therefore, ΔT is not calculated for the primary relay, and it is represented using symbol - in the tables.

TABLE 2.
Test results - Operation mode I

Fault	Relay	Conventional A.			Adaptive A. I			Adaptive A. II			Adaptive A. II			Adaptive A. II		
		TDS	t (s)	$\Delta T(s)$	TDS	t (s)	$\Delta T(s)$	TDS	t (s)	$\Delta T(s)$	$I_{P ad}$ (A)	I_F (A)	Trip	$I_{P ad}$ (A)	I_F (A)	Trip
F1	R5	0.047	0.084	-	0.047	0.084	-	0.059	0.103	-	33.18	854.34	YES	941	1255	YES
	/R8	0.038	0.212	0.395	0.038	0.212	0.395	0.044	0.523	0.420	30.07	33.09	YES	-	-	-
	/R9	0.148	0.212	0.127	0.148	0.212	0.127	0.150	0.211	0.105	16.48	821.81	YES	-	-	-
	R3	0.160	0.296	-	0.160	0.296	-	0.161	0.297	-	30.20	707.72	YES	1356	1808	YES
	/R1	0.202	0.438	0.142	0.202	0.438	0.142	0.202	0.437	0.140	85.72	1433.53	YES	-	-	-
	/R10	0.045	0.441	0.145	0.045	0.441	0.145	0.033	0.407	0.110	65.88	737.01	YES	-	-	-
F2	R4	0.149	0.202	-	0.149	0.202	-	0.150	0.336	-	33.18	854.34	YES	1221	1628	YES
	/R1	0.202	0.460	0.173	0.202	0.46	0.173	0.202	0.462	0.127	85.72	1254.36	YES	-	-	-
	/R5	0.047	0.394	0.107	0.047	0.394	0.107	0.059	0.557	0.222	33.18	297.84	YES	-	-	-
	R10	0.045	0.103	-	0.045	0.103	-	0.033	0.075	-	65.89	383.04	YES	898	1198	YES
	/R12	0.050	0.388	0.285	0.050	0.388	0.285	0.037	0.256	0.181	56.11	96.01	YES	-	-	-
	/R14	0.024	0.325	0.222	0.024	0.325	0.222	0.110	0.231	0.156	22.36	21.14	NO	-	-	-
F3	R6	0.144	0.248	-	0.144	0.248	-	0.124	0.214	-	15.02	312.62	YES	798	1064	YES
	/R8	0.038	1.227	0.979	0.038	1.227	0.979	0.044	0.379	0.111	30.07	18.99	NO	-	-	-
	/R3	0.160	0.392	0.144	0.160	0.392	0.144	0.161	0.399	0.131	30.20	297.21	YES	-	-	-
	R9	0.148	0.201	-	0.148	0.201	-	0.150	0.202	-	16.48	312.62	YES	912	1216	YES
	/R12	0.050	0.388	0.187	0.050	0.388	0.187	0.037	0.302	0.100	56.11	96.01	YES	-	-	-
	/R14	0.024	0.325	0.123	0.024	0.325	0.123	0.110	0.363	0.161	22.36	21.14	NO	-	-	-

Source: Created by the authors.

TABLE 3.
Test results - Operation mode II

Fault	Relay	Conventional A.			Adaptive A. I			Adaptive A. II			Adaptive A. II			Adaptive A. II		
		TDS	T (s)	$\Delta T(s)$	TDS	t (s)	$\Delta T(s)$	TDS	t (s)	$\Delta T(s)$	$I_{P ad}$ (A)	I_F (A)	Trip	$I_{P ad}$ (A)	I_F (A)	Trip
F1	R5	0.047	0.092	-	0.040	0.084	-	0.049	0.103	-	43.01	636.67	YES	910	1 214	YES
	/R9	0.148	0.223	0.132	0.124	0.212	0.127	0.150	0.211	0.108	23.19	649.32	YES	-	-	-
	R3	0.160	0.315	-	0.137	0.296	-	0.136	0.297	-	40.73	574.04	YES	1 343	1 791	YES
	/R1	0.202	0.469	0.174	0.177	0.438	0.142	0.175	0.437	0.110	112.95	1183.01	YES	-	-	-
	/R10	0.045	0.121	-0.175	0.16	0.441	0.145	0.146	0.407	0.110	79.38	616.05	YES	-	-	-
	R4	0.149	0.332	-	0.125	0.287	-	0.145	0.336	-	78.32	967.84	YES	1 208	1 611	YES
F2	/R1	0.202	0.446	0.159	0.177	0.460	0.170	0.175	0.462	0.127	112.95	1273.44	YES	-	-	-
	/R5	0.047	0.117	-0.170	0.040	0.394	0.109	0.049	0.557	0.222	43.01	310.34	YES	-	-	-
	R10	0.045	0.158	-	0.160	0.103	-	0.146	0.075	-	79.38	355.75	YES	873	1 164	YES
	/R12	0.050	0.410	0.307	0.057	0.388	0.285	0.088	0.256	0.181	54.68	105.94	YES	-	-	-
	R6	0.144	0.252	-	0.117	0.248	-	0.101	0.214	-	22.41	292.15	YES	774	1 032	YES
	/R3	0.160	0.386	0.137	0.137	0.392	0.144	0.136	0.399	0.185	40.73	309.73	YES	-	-	-
F3	R9	0.148	0.275	-	0.124	0.201	-	0.150	0.202	-	23.19	292.33	YES	895	1 193	YES
	/R12	0.050	0.410	0.208	0.057	0.388	0.187	0.088	0.302	0.100	54.68	105.94	YES	-	-	-

Source: Created by the authors.

TABLE 4.
Test results - Operation mode III

Fault	Relay	Conventional A.			Adaptive A. I			Adaptive A. II			Adaptive A. II			Adaptive A. II		
		TDS	T (s)	ΔT (s)	TDS	t (s)	ΔT (s)	TDS	t (s)	ΔT (s)	$I_{P\ ad}$ (A)	I_F (A)	Trip	$I_{P\ ad}$ (A)	I_F (A)	Trip
F1	R5	0.047	0.090	-	0.045	0.084	-	0.055	0.103	-	40.01	669.77	YES	931	1 241	YES
	/R8	0.038	0.184	0.094	0.082	0.480	0.395	0.066	0.523	0.420	48.62	79.89	YES	-	-	-
	/R9	0.148	0.228	0.138	0.093	0.212	0.127	0.093	0.211	0.105	45.82	589.84	YES	-	-	-
	R3	0.160	0.317	-	0.153	0.296	-	0.123	0.297	-	26.94	560.31	YES	1 340	1 787	YES
	/R1	0.202	0.468	0.151	0.172	0.438	0.142	0.170	0.437	0.140	119.32	1 195.51	YES	-	-	-
	/R10	0.045	0.119	-0.177	0.146	0.441	0.145	0.131	0.407	0.110	98.77	644.68	YES	-	-	-
	R4	0.149	0.330	-	0.138	0.287	-	0.159	0.336	-	97.94	994.91	YES	1 206	1 608	YES
F2	/R1	0.202	0.457	0.169	0.172	0.460	0.173	0.170	0.462	0.127	119.32	1 282.83	YES	-	-	-
	/R5	0.047	0.120	-0.167	0.045	0.394	0.107	0.055	0.557	0.222	29.81	294.05	YES	-	-	-
	R10	0.045	0.169	-	0.146	0.103	-	0.131	0.075	-	98.77	305.01	YES	857	1 142	YES
	R6	0.144	0.241	-	0.124	0.248	-	0.104	0.214	-	45.54	350.16	YES	792	1 057	YES
F3	/R8	0.038	0.198	-0.050	0.082	1.227	0.979	0.395	0.379	0.111	38.45	71.75	YES	-	-	-
	/R3	0.160	0.394	0.145	0.153	0.392	0.144	0.297	0.399	0.131	26.94	293.38	YES	-	-	-
	R9	0.148	0.262	-	0.093	0.201	-	0.093	0.202	-	45.82	350.28	YES	880	1 173	YES
	R3	0.160	0.394	0.145	0.153	0.392	0.144	0.297	0.399	0.131	26.94	293.38	YES	-	-	-

Source: Created by the authors.

Similarly, the results for adaptive approaches III and IV are presented in three columns; the first corresponds to the calculated $I_{P\ ad}$ value, the second is the I_F value, and the third indicates the presence of a trip signal.

4. DISCUSSION

In the case of operation mode, I, Table 2 shows that conventional and adaptive approach I present the same TDS and operation time since the I_P and I_F positive sequence is the same for both approaches, and it is used for coordination purposes. On the other hand, the adaptive approach II presents a difference in TDS and operation time because it used an adaptive fault current $I_{F\ ad}$ defined by (9).

The conventional approach keeps the I_P and TDS fixed for each operation mode. Tables 3 and 4, and Figure 3 show that protection coordination is lost for this approach and some ΔT values are below CTI . Even on some occasions, the backup protections trip faster than the primary protections, indicating a negative ΔT . This can be seen highlighted in the ΔT column of the conventional schematic in Tables 2 and 3.

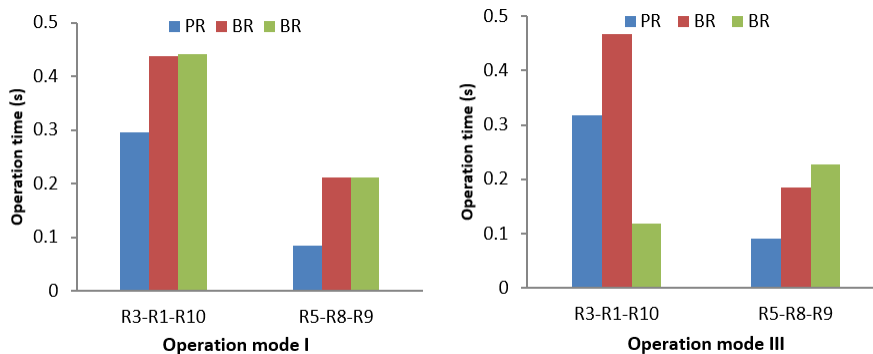

FIGURE 3.
Time operation relay primary (PR) and backup (BR)

Source: Created by the authors.

When a DER is disconnected, there are variations in I_P and I_F as shown in Figure 4. Considering that overcurrent relay operating time depends on the magnitude of the I_F , it may increase or decrease in some relays. Thus, the loss of coordination is mainly due to the change in the system operating mode.

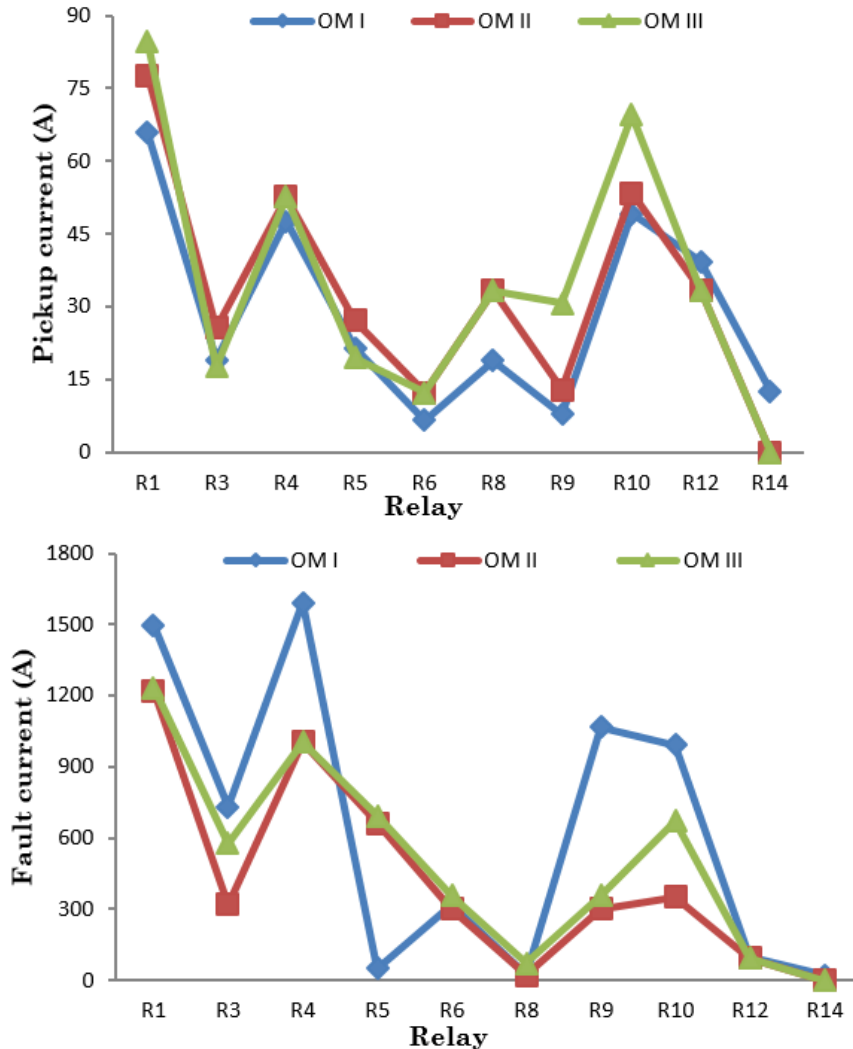

FIGURE 4. Pickup and fault current for each operation mode (OM)

Source: Created by the authors.

On the other hand, adaptive approaches I and II do not have a fixed value of I_P and TDS , since these values depend directly on the operation mode. Tables 3 and 4 show that for each operation mode and different faults, the ΔT is above the CTI . Comparing the R3 settings for F1, it can be seen in Tables 2, 3, 4, and Figure 5 that these values change for each operation mode. Therefore, the adaptive adjustments proposed in these schemes maintain the coordination between protections.

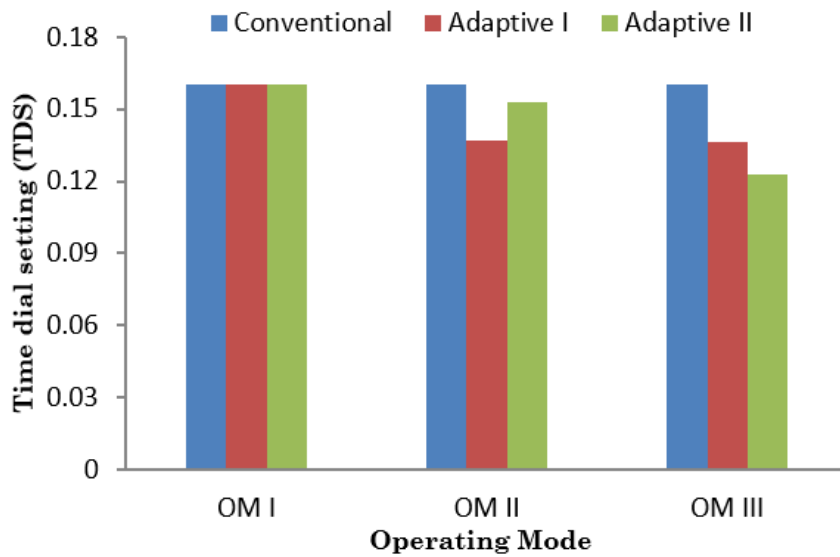

FIGURE 5.
Relay R3's TDS for each operation mode

Source: Created by the authors.

The adaptive approach III uses communication-based coordination [33]. This coordination presents a tripping logic stating that the protection element is instantaneous overcurrent, sends a trip signal when a fault occurs. The downstream relays send a blocking signal to their backup protection when these detect a fault. Once the blocking signal is received, the backup protection waits for a programmed coordination time before sending the trip signal. The backup protection will trip the local breaker if the fault continues when the programmed coordination time expires. In the case of each operation mode, the I_{p_ad} proposed is calculated depending on the active DERs and I_{mov10s} . Tables 2, 3, and 4 show that the primary protection acts the same as the backup protection for most faults. However, the relays close to the DERs do not trip for specific faults, e.g., relays R8 and R14 for operation mode I do not trip. This is because, during faults, the I_F of these sources is a maximum of two times the rated current. The approach states that if a DER is on, the maximum DER fault current contribution is considered to calculate the I_p , and for this operation mode, all the DERs are on, which leads to having an I_p more significant than the fault current.

Finally, the adaptive approach IV is evaluated for the primary protection; the backup protection is not analyzed and indicated using symbol - in tables. The proposed protection scheme calculates the I_p according to the current system operation mode and fault type, so that selective fault clearance can be guaranteed. For this approach, faults are simulated at the midpoint of the line. As a result, Tables 2, 3, and 4 show that the primary protections send a trip signal for all faults in the different operating modes. It can be seen that I_p is below the value of I_F , sending a trip signal to the breaker, clearing the fault a few cycles after it occurs.

5. CONCLUSIONS

An ADN has different operating modes depending on line contingencies, primary energy resource availability, or DERs connection/disconnection. Consequently, the conventional approach does not guarantee overcurrent relay coordination. Therefore, a robust adaptive protection approach must satisfy the reliability, selectivity, speed, economy, and safety criteria for connected and islanded mode, radial and meshed, and inverter and synchronous based DERs. In addition, the proposed algorithms must reduce their computation burden and work with the most negligible communication infrastructure.

Adaptive approaches I and II can provide a solution to coordination with calculating TDS and (IP) for each operation mode. However, these schemes use adaptive parameters estimated using the fault voltages and currents. As a result, it conduces to unacceptable delaying in the trip signal in most cases. In the case of approach III, the estimation of the $I_{p\ ad}$ presents problems in detecting faults in relays close to the DERs. On the other hand, this approach requires communication infrastructure, making the proposed scheme expensive and vulnerable to cyber-attacks. Likewise, approach IV presents an adequate performance without communication infrastructure but has a long time to detect the fault.

Finally, and as noticed, adequate ADN protection is a challenge; then, several techniques and application strategies have to be proposed shortly, where the fault identification and location strategies have to be analyzed.

ACKNOWLEDGMENTS

This paper is a result of project 6-20-6 funded by the Universidad Tecnológica de Pereira (UTP), and the project identified as contract 774-2020 (Integra2023), funded by the Colombian Ministry of Science, Technology, and Innovation (Minciencias).

REFERENCES

- [1] M. Zeyringer, J. Price, B. Fais, P.-H. Li, and E. Sharp, "Designing low-carbon power systems for Great Britain in 2050 that are robust to the spatiotemporal and inter-annual variability of weather," *Nat Energy*, vol. 3, no. 5, pp. 395–403, May 2018, <https://doi.org/10.1038/s41560-018-0128-x>
- [2] J. McDonald, "Adaptive intelligent power systems: Active distribution networks," *Energy Policy*, vol. 36, no. 12, pp. 4346–4351, Dec. 2008, <https://doi.org/10.1016/j.enpol.2008.09.038>
- [3] P. P. Barker and R. W. de Mello, "Determining the impact of distributed generation on power systems. I. Radial distribution systems," in *2000 Power Engineering Society Summer Meeting (Cat. No.00CH37134)*, Aug. 2000, vol. 3, pp. 1645–1656. <https://doi.org/10.1109/PESS.2000.868775>
- [4] S. Sarangi, B. K. Sahu, and P. K. Rout, "Review of distributed generator integrated AC microgrid protection: issues, strategies, and future trends," *Int J Energy Res*, vol. 45, no. 10, pp. 14117–14144, Aug. 2021, <https://doi.org/10.1002/er.6689>
- [5] A. Hooshyar and R. Iravani, "Microgrid Protection," in *Proceedings of the IEEE*, vol. 105, no. 7, pp. 1332–1353, Jul. 2017, <https://doi.org/10.1109/JPROC.2017.2669342>
- [6] J. D. Garzón-Hidalgo and A. J. Saavedra-Montes, "Una metodología de diseño de micro redes para zonas no interconectadas de Colombia," *TecnoLógicas*, vol. 20, no. 39, pp. 39–53, May 2017, <https://doi.org/10.22430/22565337.687>
- [7] M. Usama et al., "A Comprehensive Review on Protection Strategies to Mitigate the Impact of Renewable Energy Sources on Interconnected Distribution Networks," *IEEE Access*, vol. 9, pp. 35740–35765, Feb. 2021, <https://doi.org/10.1109/ACCESS.2021.3061919>
- [8] G. Kaur, A. Prakash, and K. U. Rao, "A critical review of Microgrid adaptive protection techniques with distributed generation," *Renewable Energy Focus*, vol. 39, pp. 99–109, Dec. 2021, <https://doi.org/10.1016/j.ref.2021.07.005>
- [9] H. Khalid and A. Shobole, "Existing Developments in Adaptive Smart Grid Protection: A Review," *Electric Power Systems Research*, vol. 191, p. 106901, Feb. 2021, <https://doi.org/10.1016/j.epsr.2020.106901>
- [10] P. H. A. Barra, D. V. Coury, and R. A. S. Fernandes, "A survey on adaptive protection of microgrids and distribution systems with distributed generators," *Renewable and Sustainable Energy Reviews*, vol. 118, p. 109524, Feb. 2020, <https://doi.org/10.1016/j.rser.2019.109524>

- [11] J. Pinheiro Nascimento, N. Silva Dantas Brito, and B. Alencar de Souza, "Proposition of an Adaptive Protection Scheme for Distribution Systems with Distributed Generation," *IEEE Latin America Transactions*, vol. 16, no. 5, pp. 1439–1444, May 2018, <https://doi.org/10.1109/TLA.2018.8408439>
- [12] M. Singh, T. Vishnuvardhan, and S. G. Srivani, "Adaptive protection coordination scheme for power networks under penetration of distributed energy resources," *IET Generation, Transmission & Distribution*, vol. 10, no. 15, pp. 3919–3929, Nov. 2016, <https://doi.org/10.1049/iet-gtd.2016.0614>
- [13] J. A. Montoya-Arias, O. A. Tobar-Rosero, G. D. Zapata-Madrigal, and R. García-Sierra, "Algoritmo adaptativo para protecciones de sobrecorriente en el caso de estudio IEEE9," *TecnoLógicas*, vol. 22, no. 45, pp. 45–58, May 2019, <https://doi.org/10.22430/22565337.1335>
- [14] J. P. Nascimento, N. S. D. Brito, and B. A. Souza, "An adaptive overcurrent protection system applied to distribution systems," *Computers & Electrical Engineering*, vol. 81, p. 106545, Jan. 2020, <https://doi.org/10.1016/j.compeleceng.2019.106545>
- [15] P. Naveen and P. Jena, "Adaptive Protection Scheme for Microgrid With Multiple Point of Common Couplings," in *IEEE Syst J*, vol. 15, no. 4, pp. 5618–5629, Dec. 2021, <https://doi.org/10.1109/JSYST.2020.3039881>
- [16] F. Coffele, C. Booth, and A. Dyśko, "An Adaptive Overcurrent Protection Scheme for Distribution Networks," *IEEE Transactions on Power Delivery*, vol. 30, no. 2, pp. 561–568, Apr. 2015, <https://doi.org/10.1109/TPWRD.2013.2294879>
- [17] H. Muda and P. Jena, "Sequence currents based adaptive protection approach for DNs with distributed energy resources," *IET Generation, Transmission & Distribution*, vol. 11, no. 1, pp. 154–165, Jan. 2017, <https://doi.org/10.1049/iet-gtd.2016.0727>
- [18] H. Muda and P. Jena, "Superimposed Adaptive Sequence Current Based Microgrid Protection: A New Technique," *IEEE Transactions on Power Delivery*, vol. 32, no. 2, pp. 757–767, Apr. 2017, <https://doi.org/10.1109/TPWRD.2016.2601921>
- [19] R. Jain, D. L. Lubkeman, and S. M. Lukic, "Dynamic Adaptive Protection for Distribution Systems in Grid-Connected and Islanded Modes," *IEEE Transactions on Power Delivery*, vol. 34, no. 1, pp. 281–289, Feb. 2019, <https://doi.org/10.1109/TPWRD.2018.2884705>
- [20] S. A. Hosseini, S. H. H. Sadeghi, and A. Nasiri, "Decentralized Adaptive Protection Coordination Based on Agents Social Activities for Microgrids With Topological and Operational Uncertainties," *IEEE Trans Ind Appl*, vol. 57, no. 1, pp. 702–713, Jan. 2021, <https://doi.org/10.1109/TIA.2020.3028351>
- [21] S. Baloch, S. S. Samsani, and M. S. Muhammad, "Fault Protection in Microgrid Using Wavelet Multiresolution Analysis and Data Mining," *IEEE Access*, vol. 9, pp. 86382–86391, Jun. 2021, <https://doi.org/10.1109/ACCESS.2021.3088900>
- [22] S. Baloch and M. S. Muhammad, "An Intelligent Data Mining-Based Fault Detection and Classification Strategy for Microgrid," *IEEE Access*, vol. 9, pp. 22470–22479, Feb. 2021, <https://ieeexplore.ieee.org/document/9344594>
- [23] R. Tiwari, R. K. Singh, and N. K. Choudhary, "Coordination of dual setting overcurrent relays in microgrid with optimally determined relay characteristics for dual operating modes," *Protection and Control of Modern Power Systems*, vol. 7, no. 1, p. 6, Feb. 2022, <https://doi.org/10.1186/s41601-022-00226-1>
- [24] S. A. F. Asl, M. Gandomkar, and J. Nikoukar, "Optimal protection coordination in the micro-grid including inverter-based distributed generations and energy storage system with considering grid-connected and islanded modes," *Electric Power Systems Research*, vol. 184, p. 106317, Jul. 2020, <https://doi.org/10.1016/j.epsr.2020.106317>
- [25] P. Dorosti, M. Moazzami, B. Fani, and P. Siano, "An adaptive protection coordination scheme for microgrids with optimum PV resources," *J Clean Prod*, vol. 340, p. 130723, Mar. 2022, <https://doi.org/10.1016/j.jclepro.2022.130723>
- [26] J. Marín-Quintero, C. Orozco-Henao, W. S. Percybrooks, J. C. Vélez, O. D. Montoya, and W. Gil-González, "Toward an adaptive protection scheme in active distribution networks: Intelligent approach fault detector," *Appl Soft Comput*, vol. 98, p. 106839, Jan. 2021, <https://doi.org/10.1016/j.asoc.2020.106839>

- [27] M.-G. Choi, S.-J. Ahn, J.-H. Choi, S.-M. Cho, and S.-Y. Yun, "Adaptive Protection Method of Distribution Networks Using the Sensitivity Analysis for Changed Network Topologies Based on Base Network Topology," *IEEE Access*, vol. 8, pp. 148169–148180, Aug. 2020, <https://doi.org/10.1109/ACCESS.2020.3015517>
- [28] J. Ma, J. Liu, Z. Deng, S. Wu, and J. S. Thorp, "An adaptive directional current protection scheme for distribution network with DG integration based on fault steady-state component," *International Journal of Electrical Power & Energy Systems*, vol. 102, pp. 223–234, Nov. 2018, <https://doi.org/10.1016/j.ijepes.2018.04.024>
- [29] M. A. Elsadd, T. A. Kawady, A.-M. I. Taalab, and N. I. Elkalashy, "Adaptive optimum coordination of overcurrent relays for deregulated distribution system considering parallel feeders," *Electrical Engineering*, vol. 103, no. 3, pp. 1849–1867, Jun. 2021, <https://doi.org/10.1007/s00202-020-01187-0>
- [30] M. Bakkar, S. Bogarra, F. Córcoles, and J. Iglesias, "Overcurrent protection based on ANNs for smart distribution networks with grid - connected VSIs," *IET Generation, Transmission & Distribution*, vol. 15, no. 7, pp. 1159–1174, Apr. 2021, <https://doi.org/10.1049/gtd2.12093>
- [31] H. Wan, K. K. Li, and K. P. Wong, "An Adaptive Multiagent Approach to Protection Relay Coordination With Distributed Generators in Industrial Power Distribution System," *IEEE Trans Ind Appl*, vol. 46, no. 5, pp. 2118–2124, Sep. 2010, <https://doi.org/10.1109/TIA.2010.2059492>
- [32] International Electrotechnical Commission, *Measuring relays and protection equipment-Part 151: Functional requirements of over/under current protection*. International Electrotechnical Commission, 2009, p. 63. [Online]. Available: <https://webstore.iec.ch/publication/1166>
- [33] IEEE, "IEEE Standard for Interconnection and Interoperability of Distributed Energy Resources with Associated Electric Power Systems Interfaces," in *IEEE Std 1547-2018 (Revision of IEEE Std 1547-2003)*, pp. 1–138, Apr. 2018, <https://doi.org/10.1109/IEEESTD.2018.8332112>

NOTES

- CONFLICTS OF INTEREST

All the authors declare no conflict of financial, professional, or personal interests that inappropriately influences the results and the interpretations here presented.

- AUTHOR CONTRIBUTIONS

B Grisales-Soto: Conceptualize, conduct the study, and manuscript preparation.

S. Pérez-Londoño: Conceptualize, verify the analytical methods, and manuscript editing.

J Mora-Flórez: Design and conduct the study.

INFORMACIÓN ADICIONAL

How to cite / Cómo citar: B. Grisales-Soto, S. Pérez-Londoño, J. Mora-Flórez, "Qualitative and Quantitative Evaluation of Overcurrent Protection in Active Distribution Systems," *Tecnológicas*, vol. 25, nro. 55, e2353, 2022. <https://doi.org/10.22430/22565337.2353>