



DYNA

ISSN: 0012-7353

Universidad Nacional de Colombia

Suvire, Gastón Orlando; Ontiveros, Leonardo Javier; Mercado, Pedro Enrique
Combined control of a flywheel energy storage system and a
vanadium redox flow battery for wind energy applications in microgrids
DYNA, vol. 84, no. 202, 2017, July-September, pp. 230-238
Universidad Nacional de Colombia

DOI: <https://doi.org/10.15446/dyna.v84n202.64705>

Available in: <https://www.redalyc.org/articulo.oa?id=49655539026>

- ▶ [How to cite](#)
- ▶ [Complete issue](#)
- ▶ [More information about this article](#)
- ▶ [Journal's webpage in redalyc.org](#)



Scientific Information System Redalyc

Network of Scientific Journals from Latin America and the Caribbean, Spain and Portugal

Project academic non-profit, developed under the open access initiative

Combined control of a flywheel energy storage system and a vanadium redox flow battery for wind energy applications in microgrids

Gastón Orlando Suvire, Leonardo Javier Ontiveros & Pedro Enrique Mercado

Instituto de Energía Eléctrica, CONICET (Consejo Nacional de Investigaciones Científicas y Técnicas)-Universidad Nacional de San Juan, San Juan, Argentina. gsuvire@iee.unsj.edu.ar, ontiveros@iee.unsj.edu.ar, pmercado@iee.unsj.edu.ar

Received: May 8th, de 2017. Received in revised form: June 27th, 2017. Accepted: August 10th, 2017

Abstract

The incorporation of wind generation in microgrids is growing progressively. This integration can introduce problems in the dynamics and power quality of the electrical system due to the wind fluctuations. This work proposes a controller composed by a power conditioning system (PCS), a Flywheel Energy Storage System (FESS) and a Vanadium Redox Flow Battery (VRFB) to palliate problems introduced by wind generation in microgrids. A model of the PCS/FESS-VRFB controller is presented and a method to control the power exchanged between the controller and the power system is suggested. The control method has two modes, namely: power levelling and frequency control. The performance of the PCS/FESS-VRFB controller is studied when it works with wind power generation in the microgrid through simulation tests. Results demonstrate suitable performance of the control methods and high effectiveness to level the wind power fluctuations and to provide support to the frequency control of the microgrid.

Keywords: flywheel energy storage system; vanadium redox flow battery; microgrid; wind power generation; power levelling; frequency control.

Control combinado de un sistema de almacenamiento de energía flywheel y una batería de flujo redox de vanadio para aplicaciones de energía eólica en microredes

Resumen

La incorporación de potencia eólica en microredes está creciendo progresivamente. Esta integración puede introducir problemas en la dinámica y calidad de potencia del sistema eléctrico debido a fluctuaciones del viento. Este trabajo propone un controlador compuesto por un sistema de acondicionamiento de potencia (PCS), un almacenador flywheel (FESS) y una batería de flujo redox de vanadio (VRFB) para mitigar problemas introducidos por la generación eólica en microredes. Se presenta un modelo del PCS/FESS-VRFB y se propone un método para controlar la potencia intercambiada entre el controlador y la red eléctrica. El método tiene dos modos: nivelación de potencia y control de frecuencia. A través de simulaciones, se estudia el desempeño del PCS/FESS-VRFB cuando opera con generación eólica en microredes. Los resultados demuestran un adecuado desempeño del método propuesto y una alta efectividad para nivelar las fluctuaciones de potencia eólica y proveer soporte para el control de frecuencia de la microred.

Palabras clave: sistema de almacenamiento de energía flywheel; batería de flujo redox de vanadio; microred; generación de potencia eólica; nivelación de potencia; control de frecuencia.

1. Introduction

The percentage of penetration of wind power generation in grid-tied microgrids (MGs) is growing [1-3]. The type of

generation system implemented by wind turbines and the fluctuating nature of the wind can have a negative effect on the dynamic security and the power quality of the MG [4-7]. To mitigate these problems, new energy storage devices

How to cite: Suvire, G.O., Ontiveros L.J. and Mercado, P.E., Combined control of a flywheel energy storage system and a vanadium redox flow battery for wind energy applications in microgrids DYNA, 84(202), pp. 230-238, September, 2017.

arise as an alternative with the purpose of compensating the power fluctuations. These energy storage systems can swiftly provide the MG with both reactive and active power simultaneously, and consequently serve to enhance the MG dynamic security and power quality [8]. There are numerous storage devices, some of which will be more convenient than others, depending on the application [7-11].

Among modern energy storage devices, Flywheel Energy Storage System (FESS) and Vanadium Redox Flow Battery (VRFB) are some of the most promising technologies. Both storage devices have quick response time, high energy efficiency, and long lifetimes. FESS has power rating in the order of MWs, and discharge time in the order of minutes. FESS stand out for their low capital cost per unit power (around 700 US\$/kW); nevertheless, it has a high capital cost per unit energy (around 2000 US\$/kWh) [10-13]. On the other hand, VRFB has power rating in the order of MWs, and discharge time in the order of hours. In contrast to FESS, VRFB is remarkable for its low capital cost per unit energy (approximately 600 US\$/kWh) and its high capital cost per unit power (2500 US\$/kW) [10,11,13].

Many solutions using FESS or VRFB devices have been proposed in the bibliography either to smooth wind power fluctuations or to provide ancillary services [14-22]. Reference [14] proposes a novel control strategy using flywheel energy storage to smooth the power injected by wind generators. In [15], a direct torque control for an induction machine used in flywheel storage is proposed to compensate the power fluctuations of a variable-speed wind generator. Reference [16] proposes a multi-level control for a controller composed by a DSTATCOM and a FESS in order to enhance the integration of wind power generation in electrical networks. In [17], control strategies using a fuzzy logic supervisor with FESS are developed in order to smooth the rapid fluctuations of wind power and to provide ancillary services. Reference [18] presents a control strategy for the frequency regulation in a wind-diesel powered MG using flywheels and fuel cells. In [19], a VRFB is proposed to improve the power quality and the stability of the power system that include wind power generation. Reference [20] highlights the alternative to spilling wind to provide frequency response capability using wind farm with VRFB. Reference [21] proposes a methodology for the economic optimization of the sizing of a VRFB whilst enhancing the participation of wind power plants in network primary frequency control support. In [22], a thyristor-based flexible ac transmission system is proposed and developed for controlling the exchange of active power flow between the VRFB and the grid in order to compensate the wind power variations generated by DFIG turbines. Although the papers mentioned present practical solutions to improve the integration of wind power generation using FESS or VRFB devices, they do not use both devices combined taking advantage of the better characteristics of each device. Nor do they perform a combined active power control in order to level the power oscillations of wind generation and provide ancillary services so as to participate in frequency control.

Based on the previous discussion, this work proposes the use of an integrated controller constituted by a FESS and a VRFB for better integration of wind power systems in

microgrids. This integrated controller also includes a power conditioning system (PCS) in order to connect the FESS-VRFB to the ac power system. To implement the PCS/FESS-VRFB controller, requires administration of the energy stored in the FESS and VRFB devices so that these devices always have the capacity to deliver or store energy. In this manner, a function that can efficiently manage the stored energy is essential. This function, carried out via a control strategy for the active power of the PCS/FESS-VRFB, has to accomplish two aims simultaneously: smooth the wind power fluctuations injected into the MG effecting a suitable use of the stored energy, and assist the frequency control in case of perturbations in the MG.

The objective of this work is to elaborate an effective control methodology of the controller proposed both to level the power fluctuations injected by wind generators in the MG and to contribute to the frequency control of the system in case of perturbations in the MG. For this purpose, while considering the characteristics and costs of each storage device, a control is proposed so that the FESS works applying frequency control when important faults occur in the MG (the storage device requires low energy and much power); and the VRFB works effecting power levelling (the storage device requires much energy and low power). The control method proposed includes two control modes of the PCS/FESS-VRFB controller, namely: power levelling (carried out by the VRFB), and frequency control (carried out by the FESS). For both proposed control modes, the charge status of each storage system is considered. The dynamic performance of the developed control method and its effect on the operation of the MG is validated by computer simulation the MATLAB/Simulink, by using SimPowerSystems and C++ codes.

2. Modelling of the PCS/FESS-VRFB controller

A model of the PCS/FESS-VRFB controller proposed for this study consists mainly of the PCS, the FESS and the VRFB. The PCS is the power electronic interface between the FESS-VRFB and the ac electric utility grid, pointing at reaching three aims: one is to convert electric power from the FESS to the ac grid, another is to convert the dc voltage of the VRFB to the ac grid, and the final one is to efficiently load/unload the FESS and VRFB storages. The diagram of the proposed modelling of the PCS/FESS-VRFB controller is shown in Fig. 1.

The PCS proposed is integrated by a back-to-back ac/dc/ac converter (composed of two voltage source inverters). The proposed inverter structure to the ac/dc/ac converter is based on a two-level six-pulse topology. Moreover, it uses sinusoidal pulse width modulation techniques to control the output voltage control of the VSI. The chopper consists of a buck-boost converter, which is commonly used when the magnitude of two dc bus voltages is close to each other and the voltage ratio is smaller or greater than unity and it does not vary significantly. The power exchange between the flywheel and the ac/dc/ac converter is carried out through a permanent magnet synchronous machine (PMSM). The flywheel is modelled as an additional mass coupled to the rotor shaft of the PMSM

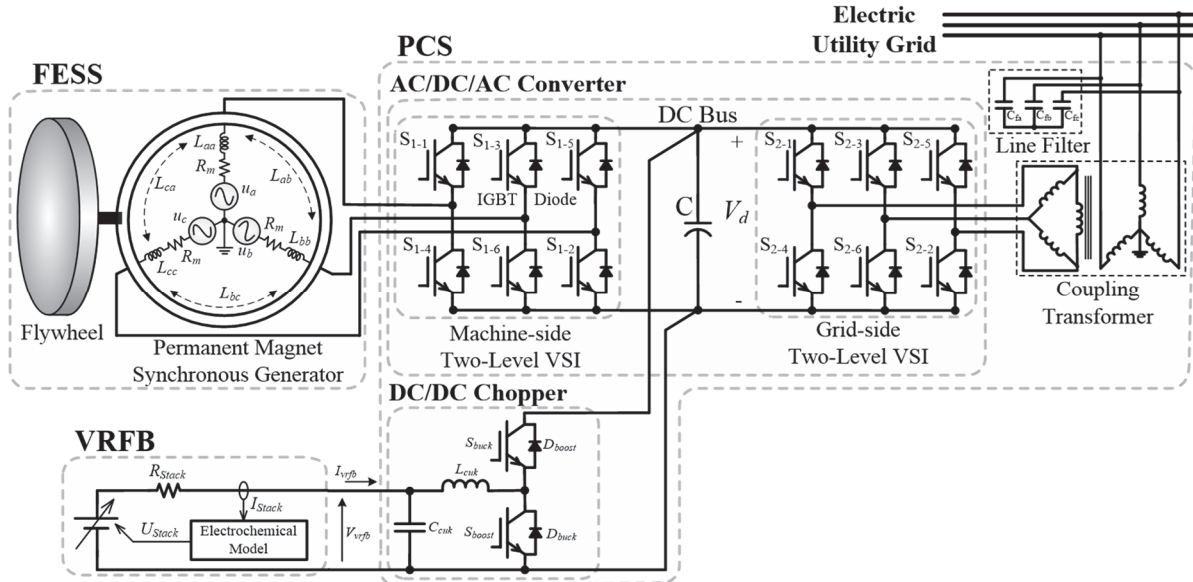

Figure 1. Model of the proposed PCS/FESS-VRFB controller.
Source: Authors

[23]. The FESS model with its PCS is comprehensively analysed in [16]. The VRFB model is composed of two parts: the stack model (electrochemical model), and the mechanical model. In the stack model, the terminal VRFB current (I_{VRFB}) determines the stack current (I_{stack}) and consequently, the terminal stack voltage (U_{stack}) and the state of charge (soc) of the electrolyte. In the mechanical model, the external control system sets the flow rate that produces a pressure drop in the hydraulic system. The VRFB model with its PCS is comprehensively analysed in [22].

3. Control system

The control proposed for the PCS/FESS-VRFB controller is divided into three: the Chopper control, the machine-side VSI control, and the grid-side VSI control. For each control, a multi-level scheme is suggested [24,25]. The multi-level control scheme of the chopper is divided into two levels: internal and middle levels; and the multi-level schemes of the machine-side VSI and the grid-side VSI are divided into three levels: internal, middle and external levels. The control system of the PCS/FESS-VRFB controller is shown in Fig. 2. The control algorithm for the flywheel energy storage is fully developed in [16], and for the VRFB and chopper in [22]. Only the external level of the grid-side VSI control (bottom, right-hand corner of Fig. 2) is presented below which is the main contribution of this work.

The external level control of the grid-side VSI is in charge for establishing the power exchange between the grid-side VSI and the electric power system [16,24]. The external level control has the following modes of operation of the PCS/FESS-VRFB: power levelling (PL), frequency control (FC), and voltage control (VC). The PCS/FESS-VRFB controller constantly works in VC and PL modes with the VRFB connected and the FESS in standby; enhancing the power quality generated by wind power generators. When

significant frequency deviations take place, the FC mode is active, helping to recuperate the rated system frequency and thus improving the grid security. In the FC mode, the FESS is activated. In this work, only the PL and FC modes are developed, which are the core of the contribution.

3.1. Power levelling

The objective of controlling the active power stored or generated by the storage system (mainly the VRFB) is to level the fluctuations of wind power and to manage the energy stored properly so that the VRFB storage device always has capacity to deliver or store energy. Therefore, the control is designed considering the wind power generation and the state of charge of the VRFB. Fig. 2 (PL block) shows the structure of the power levelling control.

The first step to enable the control is to level the power of the wind generators. This is carried out by eliminating the turbulent component (P_t) of the wind power (PWG). For this, a low-pass filter with a cut-off frequency at 1 cycle/h is used to obtain the diurnal and synoptic component of the wind power (P_{ds}) [22]. Then, the P_{ds} is passed by a regulator to obtain the levelling power regulated. The purpose of this regulator is to compute the value of a regulation power, P_{reg} (desired power from WGs plus VRFB). Finally, the power generated by wind system, PWG, is subtracted from the P_{reg} , and thus the reference power, P_{ref2} , is obtained. This P_{ref2} must either be stored or generated by the VRFB.

The state of charge, soc , and the filtered value of wind power generation, P_{ds} , are the inputs of the regulator. The regulator is built according to the following rules:

- 1) If the soc of the VRFB is exhausted, then the charge of the VRFB will be prioritized.
- 2) If the soc of the VRFB is almost complete, then the discharge of the VRFB (power generation) will be prioritized.

- 3) If the *soc* of the VRFB is half, then either charge or discharge of the VRFB will be not prioritized. The electric power system receives the wind power fluctuations levelled by the VRFB.

Using eq. (1), the regulator calculates the P_{reg} , as a function of the *soc* and P_{ds} . Moreover, the regulator is done while taking into account that the *soc* can only work between 0.2 and 0.8 of the maximum *soc* [22]. Fig. 3 shows the evolution of P_{reg} according to the *soc* and the P_{ds} .

$$P_{reg} = \frac{5}{6}soc + \frac{P_{ds}}{2} - \frac{1}{6} \quad (1)$$

3.2. Frequency control

The frequency control is in charge of establishing the power exchange between the storage system (mainly the FESS) and the electric power system when faults in the system cause significant deviations in the frequency. The frequency control is responsible for minimizing the duration and magnitude of system disturbances by absorbing power imbalances caused by the fault, with the purpose of keeping the system frequency higher than the minimum level. Fig. 2 shows the structure of the frequency control (FC block).

The measured frequency of the system, f_s , is compared with a reference frequency, f_r . A dead-band block (DB) is used with the aim of determining the entry of the FESS in the frequency control of the electric power system. The output current signal i_{pr1} depicts the active current flow that the FESS needs to inject for compensating the frequency shift of the electrical system.

In accordance with the FC mode, the FESS should be in some measure charged at a specific rating to permit power to be injected or absorbed into or from the grid at any time. This allows for the balancing negative and positive power variations in the electrical system. The level of charge of the FESS is controlled by considering the power flow in the line that connects the MG to the electric utility grid (P_{grid} in Fig. 2). If P_{grid} goes from the electric utility grid to the PCC, a disconnection of the line causes a decrease in the frequency of the MG (the FESS should be charged so that energy can be injected); and if P_{grid} goes from the PCC to the electric utility grid, a disconnection of the line causes an increase in the frequency of the MG (the FESS should be discharged so that energy can be absorbed). Therefore, the P_{grid} determines the initial state of charge (ω_{r_in}) of the FESS. The control schematized in Fig. 4 is used to calculate the ω_{r_in} . The ω_{r_in} is cancelled when frequency deviation exceeds the dead-band value in order to prioritize the frequency regulation, as described in Fig. 2 with the state 0/1 outgoing from the DB block.

The control schematized in Fig. 4 is designed with the following criteria:

- 1) If P_{grid} goes from the electric utility grid to PCC, the FESS must be charged to the maximum charge to provide energy in case the frequency drops down by the disconnection of the line. In this case, 0.9 of the maximum value of the state of charge is adopted.
- 2) If P_{grid} goes from the PCC to electric utility grid, the FESS must be charged to the minimum charge to absorb

energy in case of the frequency rises by the disconnection of the line. In this case, 0.1 of the maximum value of the state of charge is adopted.

- 3) If P_{grid} is close to zero (for one side or another), the state of charge varies linearly with P_{grid} , among adopted values +/- 0.2 of the maximum power of the controller. 0.2 P_{c_max} is chosen due to: A) at lower values, the FESS could go from maximum to minimum load (and vice versa) extremely quickly, and B) at higher values, the FESS could be working constantly since the reference is always changing. In addition, a low pass filter (LPF2) is placed at the output of this control block to limit abrupt changes in the reference due to variations when the power is close to zero.

4. Test power system

The test power system employed to validate the proposed control methodology of the PCS/FESS-VRFB controller for enhancing the incorporation of wind power generators in MGs is shown in Fig. 5. This electrical network implements a MG connected through a 20 km transmission line and a transformer to a bulk power system represented by a single machine-infinite bus type system. The MG consists of different distributed energy resource units (distributed generation based on renewable and fossil fuels and the advanced PCS/FESS-VRFB controller) and loads.

The distributed generation based on renewable resources consists of a wind farm integrated by three rows of wind turbines with three turbines per row. The technology used by each wind turbine corresponds to a variable speed wind turbine with full-scale frequency converter. The rated power of the wind farm is 9MW (each wind turbine has 1 MW rated power). The distributed generation based on fossil fuel (50 MVA rated power) consists of a dispatchable unit powered by multi-stage tandem compound steam turbine and includes a speed governor and a voltage regulator. All loads are grouped at bus 5. The proposed controller is placed at bus 2, representing the point of common coupling of the wind farm (PCC-WF) to the rest of the ac microgrid, and includes a ± 10 MVA/750 V dc bus PCS, a 6 MW/60 MJ FESS system, and a 2 MW/3600 MJ VRFB system. Full test system data are included in [16,17,22].

The testing of the control proposed for the PCS/FESS-VRFB controller in grid-tied operation is done through two case studies that demand a high dynamic response of the controller. The first case analyses the behaviour of the control of the PCS/FESS-VRFB when a real profile of wind speed is established to the wind turbines so that the PCS/FESS-VRFB controller operates continuously by delivering and storing energy. In this case, the behaviour of the PL control mode and the operation of the VRFB is mainly shown. In the second case, the PCS/FESS-VRFB controller is tested when external perturbations are imposed on the bulk power system, so that the microgrid is changed to islanded operation mode and major frequency shifts occur. In this case, the behaviour of the FC control mode and the operation of the FESS are mainly observed.

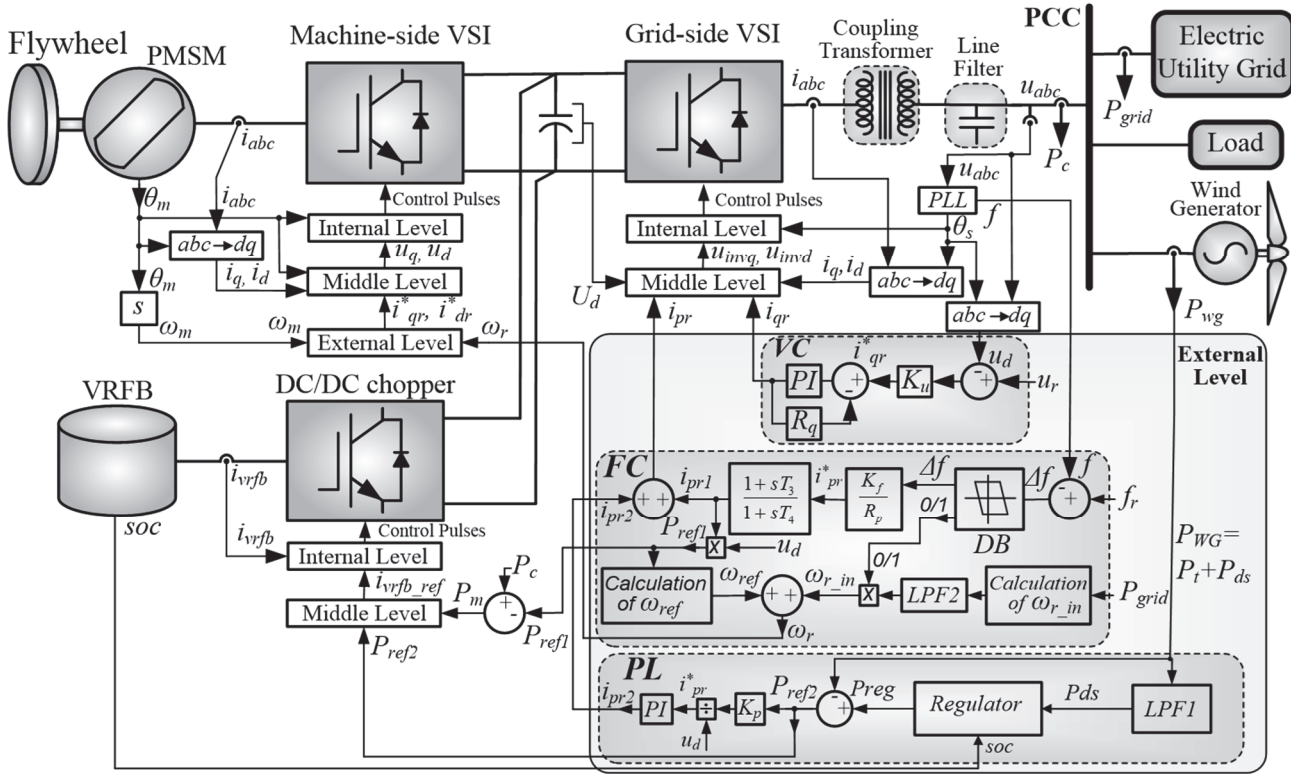

Figure 2. Control structure of the PCS/FESS-VRFB controller.
Source: Authors

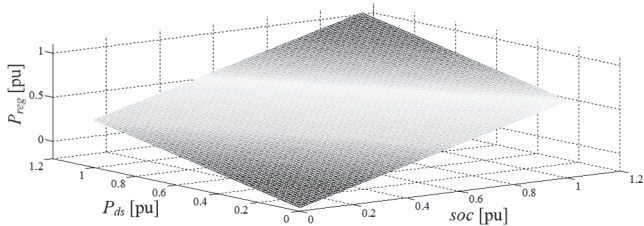

Figure 3. P_{reg} against soc and P_{ds} , obtained with the proposed regulator.
Source: Authors

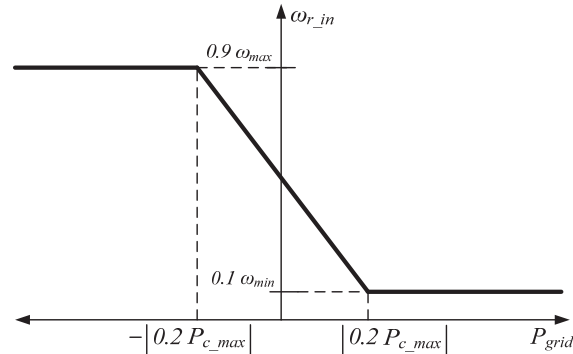

Figure 4. Calculation of the initial state of charge of the FESS.
Source: Authors

5. Digital simulation results

5.1. PCS/FESS-VRFB performance analysis working in PL mode

For this case study, the test power system shown in Fig. 5 is used. A suitable profile for fluctuation of the wind speed is applied. This profile has a variable mean value of the wind speed, so that the wind farm (WF) operates near the minimum and maximum power. The active power flow for the system WF plus PCS/FESS-VRFB, with the PCS/FESS-VRFB controller unplugged and plugged, is shown in Fig. 6(a). It is observed how the PCS/FESS-VRFB controller reduces the wind power fluctuations with the proposed PL control mode, avoiding these perturbations from being injected into the electric power system.

In this case, the VRFB is working on the PL control mode, and the FESS device is on stand-by. Fig. 6(b) shows the active power injected by the VRFB device. It can be noted that the rapid active power variations injected by the VRFB device aptly countervail the wind power fluctuations. Besides, the PCS/FESS-VRFB controller notably achieves such damping without the VRFB power exceeding ± 2 MW (rated power of the VRFB).

Finally, the performance of the state of charge (soc) of the VRFB is shown in Fig. 6(c). It can be highlighted that, with the control system proposed, the soc does not exceed the maximum charge (overloaded state) and does not drop lower than the minimum charge (no load state).

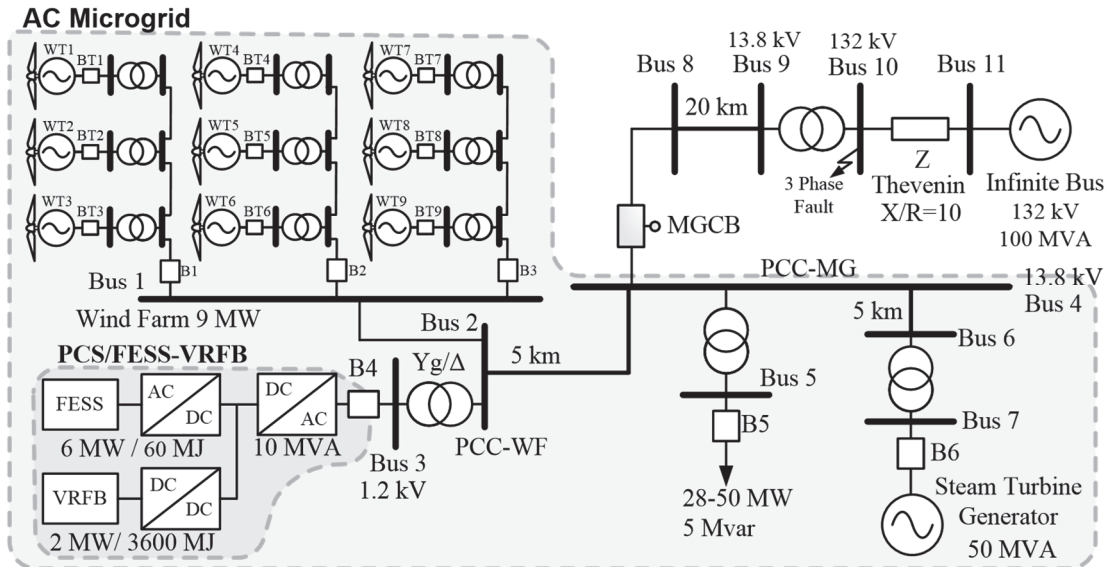

Figure 5. Diagram of the test power system with a microgrid including wind power generation and the PCS/FESS-VRFB controller. Control structure of the PCS/FESS-VRFB controller.
Source: Authors

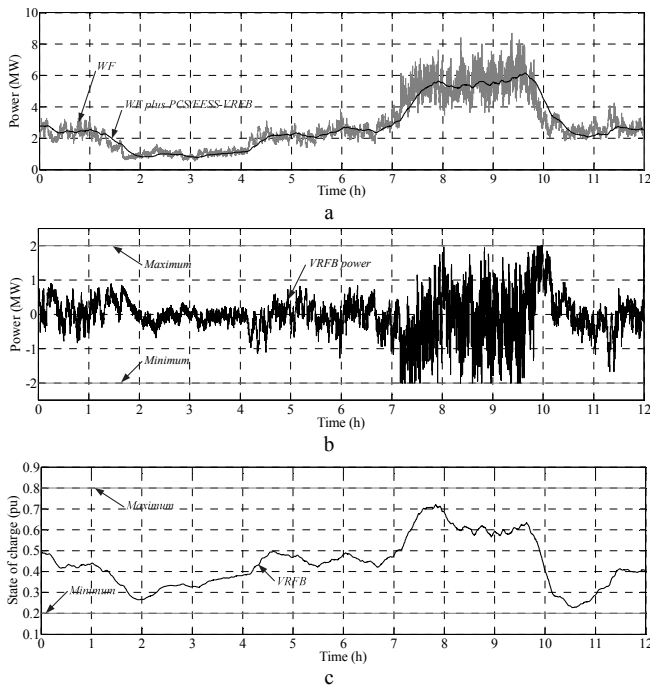

Figure 6. Results for the PCS/FESS-VRFB performance working in PL mode
a. Active power flow for the WF alone and with the PCS/FESS-VRFB controller connected
b. Active power injected by the VRFB
c. State of charge of the VRFB
Source: Authors

5.2. PCS/FESS-VRFB Performance Analysis working in FC mode

The operation of FC mode is analysed by using the same test power system of Fig. 5. To carry it out, a ground fault is

enforced at bus 10 (at $t=10.1$ s). Five cycles later, i.e. at $t=10.2$ s, with the tripping of the tie line through the opening of the breaker MGCB, the fault is cleared.

For this situation, two appropriate scenarios are considered. In the first one, the MG has a high load (50 MW) and low wind for the wind farm ($P_{WG} = 1$ MW); and in the second one, the MG has a low load (28 MW) and high wind for the wind farm ($P_{WG} = 7.5$ MW). The results for each of these scenarios are shown in Figs. 7, 8, respectively.

For the test system presented in Fig. 5, before the fault, the microgrid (wind farm, steam turbine, load and the PCS/FESS-VRFB controller) imports about 14 MW from the bulk power system (for the first scenario), and exports about 14 MW to the bulk power system (for the second scenario). In this state, the frequency of the system is at 50 Hz (its rated value) in both scenarios. After the opening of the MGCB breaker, the microgrid works under island conditions. In this manner, the steam turbine and the wind farm have to supply all the load; therefore, the steam turbine must automatically recover the microgrid frequency to its rated value. Figs. 7(a), 8(a) show, for both considered scenarios respectively, how the steam turbine unit can recover the frequency of the system in the base case (without the PCS/FESS-VRFB controller).

Now, the operation of the PCS/FESS-VRFB with 6 MW rated power and 60 MJ rated storage capacity for the FESS device is considered. The results of Figs. 7(a), 8(a) clearly show the working of the PCS/FESS-VRFB controller and the outstanding performance of the proposed control. After the opening of the MGCB breaker, when the microgrid frequency shift surpasses the DB limits (0.15 Hz), the FC mode and the FESS device are activated. The rapid power generation/consumption of the FESS supplies the sudden imbalance occurred in the microgrid after the fault. This condition allows for a better recovery of the microgrid frequency. For the first scenario, in the case with the FESS connected, the system frequency drops to nearly 49.23 Hz

against 48.82 Hz in the base case. And for the second scenario, in the case with the FESS connected, the system frequency rises to nearly 50.64 Hz against 51.11 Hz in the base case.

The enhancement of the frequency control is achieved by the action of the PCS/FESS-VRFB controller (working the FESS device in the FC mode), which generates/consumes power for about 14.5 s. Moreover, after the frequency places within the limits of the DB value, the PL mode is activated again. This causes reductions in fluctuations of wind power and, consequently, decreases in the small frequency shifts of the microgrid.

The active power injected by the FESS for both scenarios are shown in Figs. 7(b), 8(b), respectively. It can be observed that after the opening of the MGCB breaker, the FESS generates/stores its maximum power. Therefore, the wind farm with the PCS/FESS-VRFB and the proposed control assists to the recovery of the microgrid frequency. The rotational speed for the FESS (state of charge) for both scenarios is shown in Figs. 7(c), 8(c), respectively. A clear decrease/increase of the state of charge during the fault owing to the energy generation/consumption is easily observable. It can be noted in these figures that the FESS speed previous to the fault is high for the first scenario and low for the second scenario. Hence, it distinguishes a good performance of the proposed control in order to have energy to store or generate, depending on the power flow of the tie line to the utility grid. Finally, the active power injected by the synchronous generator of the steam turbine with and without the connection of the PCS/FESS-VRFB controller for both scenarios are shown in Figs. 7(d), 8(d), respectively. It is easily recognizable from these figures that with the operation of the PCS/FESS-VRFB controller the working of the synchronous generator of the steam turbine is significantly enhanced.

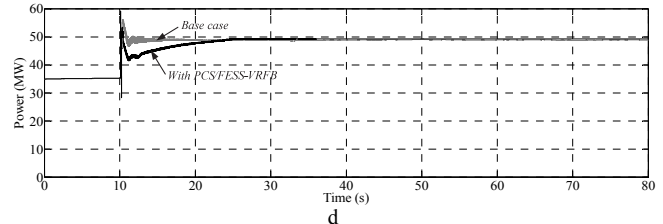
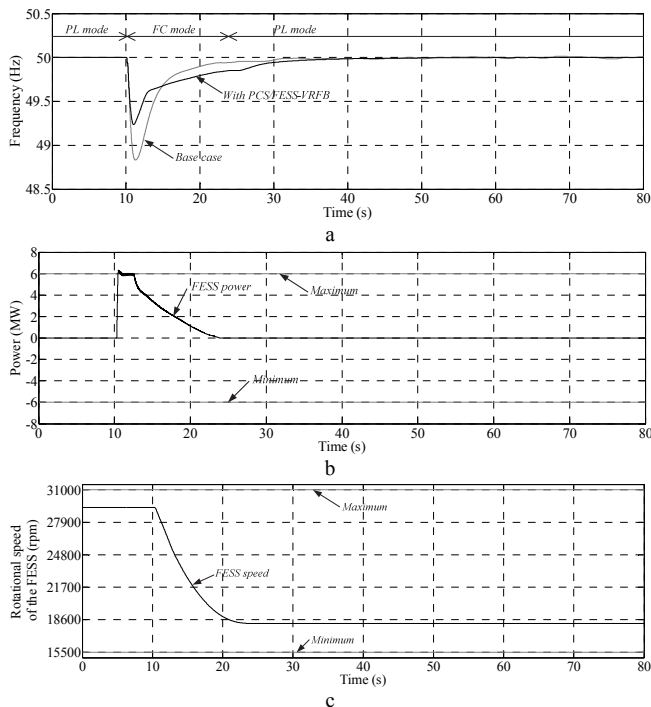

Figure 7. Results for the PCS/FESS-VRFB performance working in FC mode, first scenerly (high load and low wind power)

- a. System frequency
 - b. Active power injected by the FESS
 - c. Rotational speed of the FESS
 - d. Active power of the synchronous generator of the steam turbine
- Source: Authors

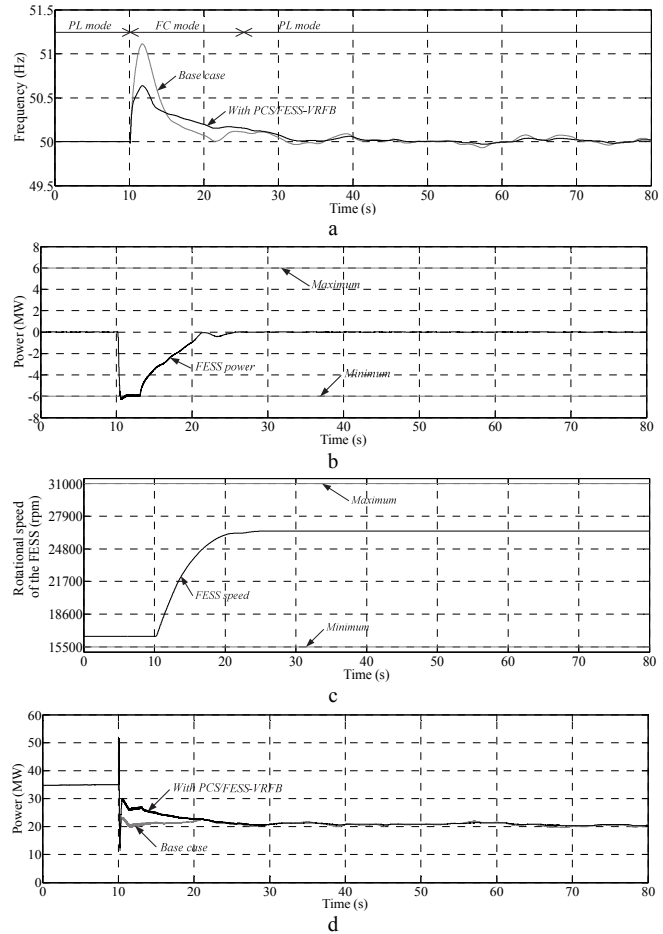

Figure 8. Results for the PCS/FESS-VRFB performance working in FC mode, second scenerly (low load and high wind power)

- a. System frequency
 - b. Active power injected by the FESS
 - c. Rotational speed of the FESS
 - d. Active power of the synchronous generator of the steam turbine
- Source: Authors

6. Conclusions

This work presents control aspects of a controller composed by a power conditioning system (PCS), a Flywheel Energy Storage System (FESS) and Vanadium Redox Flow Battery (VRFB) to enhance the integration of wind power

generation into ac microgrids. A control method of the PCS/FESS-VRFB controller is proposed using two control modes, power levelling (PL) and frequency control (FC). The PL control mode uses a low-pass filter with a particular function to level the power fluctuations injected by wind generators into an electric power system. The FC control mode is employed to assist to the frequency control when significant faults occur in the system.

From the results achieved, authors concluded that the developed control methods operate satisfactorily. The PCS/FESS-VRFB controller, with the operation of the VRFB, effectively countervails the wind power fluctuations. The WF plus PCS/FESS-VRFB generates a more levelled power than that of the wind farm alone without the PCS/FESS-VRFB. Moreover, the WF plus PCS/FESS-VRFB, now with the operation of the FESS, also contributes to the recovery of the frequency when important faults take place in the system. In reference to the PL control mode, it is possible to conclude that the active power control of the VRFB using a regulator reach an outstanding handling of the stored energy, by correcting the fluctuations of wind power and avoiding the VRFB from becoming discharged or overcharged. With PL mode, the power quality of wind farms is enhanced and a suitable utilization of the energy stored for the VRFB is reached. In the FC mode, when the microgrid is isolated due to faults, causing the frequency rises or falls over a given value; the PCS/FESS-VRFB changes from PL to FC control mode conclusively, thereby activating the FESS device, and successfully contributing to recovering the microgrid frequency at its rated value. With the FC mode, excellent handling of the stored energy for the FESS is also notable, having available energy to store or generate to deal with power imbalances properly when the microgrid is isolated. In the FC mode, the wind farm with the PCS/FESS-VRFB controller provide an ancillary service to enhance the system security of the microgrid. Finally, it is clearly distinguished that optimal usage of energy storage devices is achieved with the PCS/FESS-VRFB and the control proposed. The best characteristics of the energy storage devices have been considered depending on the application. For load levelling, the VRFB is used contemplating their high discharge times, low capital cost per unit energy and high capital cost per unit power. And for frequency control, the FESS is used primarily considering their fine values of power rating, the low capital cost per unit power and high capital cost per unit energy. Hence, the incorporation of wind power generation in microgrids is efficiently enhanced with the compensation of the PCS/FESS-VRFB controller.

References

- [1] Mathiesen, B.V., Lunda, H. and Karlsson, K., 100% Renewable energy systems, climate mitigation and economic growth. *Applied Energy*, 88(2), pp. 488-501, 2011. DOI: 10.1016/j.apenergy.2010.03.001
- [2] Sivachandran, P. and Muthukumar R., An overview of microgrid system. *International Journal of Applied Engineering Research*, [online]. 9(22), pp. 12353-12376, 2014. [date of reference October of 2016]. Available at: <https://www.ripublication.com/Volume/ijaerv9n22.htm>
- [3] Mohamed, E. and El-H., The smart grid—State-of-the-art and future trends. *Electric Power Components and Systems*, 42(3–4), pp. 239-250, 2014. DOI: 10.1080/15325008.2013.868558
- [4] Ackermann, T., *Wind power in power systems*. John Wiley & Sons, London, UK, 2005.
- [5] Matos, J.G., Silva, F.S.F. and Ribeiro, L.A., Power control in AC isolated microgrids with renewable energy sources and energy storage systems. *IEEE Transactions on Industrial Electronics*, 62(6), pp. 3490-3498, 2015. DOI: 10.1109/TIE.2014.2367463
- [6] Skander-Mustapha, S., Jebali-Ben, G.M., Arbi, J. and Slama-Belkhdja, I., Comparative analysis of control strategies for DFIG based wind system under small grid faults. *International Review of Electrical Engineering (IREE)*, [online]. 4(6), pp. 1273-1282, 2009. [date of reference October of 2016]. Available at: https://www.researchgate.net/publication/286863896_Comparative_analysis_of_control_strategies_for_DFIG_based_wind_system_under_small_grid_faults
- [7] Molina, M.G., Suvire, G.O., Ontiveros, L.J. and Mercado, P.E., Emerging energy storage technologies in utility power systems: A technical insight, in *energy storage*, 1st ed, chapter N° 6, Rosen, M.A., Ed. Nueva York: Nova Science Publishers Inc., 2012, pp. 235-312.
- [8] Abedini, A. and Nikkhajoei, H., Dynamic model and control of a windturbine generator with energy storage. *IET Renewable Power Generation*, 5, pp. 67-78, 2011. DOI: 10.1049/iet-rpg.2009.0123
- [9] Vazquez, S., Lukic, S.M., Galvan, E., Franquelo, L.G. and Carrasco, M., Energy storage systems for transport and grid applications. *IEEE Transactions on Industrial Electronics*, 57(12), pp. 3881-3895, 2010. DOI: 10.1109/5.975900
- [10] The Electricity Storage Association, www.electricitystorage.org, accessed October 2016
- [11] The Sandia National Laboratories - Energy Storage Systems, [online]. Available at: <http://www.sandia.gov/ess/> accessed October 2016
- [12] Suvire, G.O. and Mercado, P.E., Energy storage for wind power: A comparative analysis considering the type and size of the wind system. 18th International Conference on Intelligent System Applications to Power Systems (ISAP), Porto, Portugal, September 2015, pp. 1-6. DOI: 10.1109/ISAP.2015.7325558
- [13] Sundararagavan, S. and Baker, E., Evaluating energy storage technologies for wind power integration. *Solar Energy*, 86(9), pp. 2707-2717, 2012. DOI: 10.1016/j.solener.2012.06.013
- [14] Cárdenas, R., Peña, R., Asher, G.M., et al., Control strategies for power smoothing using a flywheel driven by a sensorless vector-controlled induction machine operating in a wide speed range. *IEEE Transactions on Industrial Electronics*, 51(3), pp. 603-614, 2004. DOI: 10.1109/TIE.2004.825345
- [15] Cimuca, G., Breban, S., Radulescu, M.M., et al. Design and control strategies of an induction-machine-based flywheel energy storage system associated to a variable-speed wind generator. *IEEE Transactions on Energy Conversion*, 25(2), pp. 526-534, 2010. DOI: 10.1109/TEC.2010.2045925
- [16] Suvire, G.O. and Mercado, P.E., DSTATCOM with flywheel energy storage system for wind energy applications: Control design and simulation. *Electric Power Systems Res.*, 80(3), pp. 345-353, 2010. DOI: 10.1016/j.epsr.2009.09.020
- [17] Suvire, G.O. and Mercado, P.E., Combined control of a DSTATCOM/FESS for wind energy applications. *IET Generation, Transmission & Distribution*, 6(6), pp. 483-492, 2012. DOI: 10.1049/iet-gtd.2011.0148
- [18] Vidyandandan, K.V. and Senroy, N., Frequency regulation in a wind-diesel powered microgrid using flywheels and fuel cells. *IET Generation, Transmission & Distribution*, 10(3), pp. 780-788, 2016. DOI: 10.1049/iet-gtd.2015.0449
- [19] Ge, B., Wang, W., Bi, D., et al., Energy storage system-based power control for grid-connected wind power farm. *Electrical Power and Energy Systems*, 44(1), pp. 115-122, 2013. DOI: 10.1016/j.ijepes.2012.07.021
- [20] Banham-Hall, D., Taylor, G., Smith, C. and Irving, M., Flow batteries for enhancing wind power integration. *IEEE Transactions on Power Systems*, 27(3), pp. 1690-1697, 2012. DOI: 10.1109/TPWRS.2012.2185256
- [21] Lewis-Johnston, L., Díaz-González, F., Gomis-Bellmunt, O., et al. Methodology for the economic optimisation of energy storage systems for frequency support in wind power plants. *Applied Energy*, 137, pp. 660-669, 2015. DOI: 10.1016/j.apenergy.2014.09.031
- [22] Ontiveros, L.J. and Mercado, P.E., Thyristor-based flexible ac

transmission system for controlling the vanadium redox flow battery. IET Renewable Power Generation, 7(3), pp. 201-209, 2013. DOI: 10.1049/iet-rpg.2012.0361

- [23] Samineni, S., Johnson, B.K., Hess, H.L. and Law, J.D., Modeling and analysis of a flywheel energy storage system for voltage sag correction. IEEE Trans. Ind. Appl., 42, pp. 42-52, 2006. DOI: 10.1109/IEMDC.2003.1210699
- [24] Molina, M.G., Mercado, P.E. and Watanabe, E.H., Static synchronous compensator with superconducting magnetic energy storage for high power utility applications. Energy Convers. Manage., 48(8), pp. 2316-2331, 2007. DOI: 10.1016/j.enconman.2007.03.011
- [25] Rashid, M.H. Power Electronic Handbook. New York: Academic, 2001.

G. Orlando-Suivre, was born in San Juan, Argentina. He graduated as BSc. an Electric Eng. from the National University of San Juan (UNSJ), Argentina, in 2002 and received the PhD. degree from the same university in 2009, carrying out part of his doctorate in the COPPE institute, at the Federal University of Rio de Janeiro in Brazil, supported by CAPES. From 2009 to 2011, he worked as a postdoctoral research fellow from the Argentinean National Council for Science and Technology Research (CONICET) at the Institute of Electrical Energy (IEE), UNSJ. He is currently an assistant professor of Electrical Engineering at UNSJ. His research interests include simulation methods, power systems dynamics and control, power electronics modeling and design, and the application of wind energy and energy storage in power systems.

ORCID: 0000-0002-7869-6250

L. J. Ontiveros, was born in San Juan, Argentina, on October 9, 1977. He graduated as BSc. an Electronic Eng. from the National University of San Juan (UNSJ), Argentina in 2004. He is currently a PhD. candidate in Electrical Engineering from the same University, carrying out part in the COPPE institute, in the Federal University of Rio de Janeiro in Brazil. His research interests include simulation methods, power systems dynamics and control, power electronics modeling and design, and the application of wind energy and energy storage in power systems.

ORCID: 0000-0003-1949-6934

P.E. Mercado, (M'02–SM'02) was born in San Juan, Argentina. He graduated as BSc. an Electromechanical Eng. from the UNSJ, and received the PhD. degree from the Aachen University of Technology (RWTH), Germany. He is currently full professor with tenure of Electrical Engineering at the UNSJ and an associate researcher of the CONICET. His research activities focus on operation security, power electronics, renewable energy systems, and economic operation and control of electric power systems. Dr. Mercado is a Senior Member of the IEEE Power Engineering Society and the Power Electronics Society.

ORCID: 0000-0001-7107-091X



UNIVERSIDAD NACIONAL DE COLOMBIA

SEDE MEDELLÍN
FACULTAD DE MINAS

Área Curricular de Ingeniería
Eléctrica e Ingeniería de Control

Oferta de Posgrados

Maestría en Ingeniería - Ingeniería Eléctrica

Mayor información:

E-mail: ingelcontro_med@unal.edu.co
Teléfono: (57-4) 425 52 64