



Journal of Aerospace Technology and Management

ISSN: 1984-9648

secretary@jatm.com.br

Instituto de Aeronáutica e Espaço
Brasil

Sudheer Babu, Aleti; Kumar Mishra, Kameshwar; Laxman Jawale, Sudhir; Dattatreya Kshirsagar, Prakash; Shekhar, Himanshu
Thermoelectric-Sourced Programmable Electronic Switching Module to Ignite Electro-Explosive Devices
Journal of Aerospace Technology and Management, vol. 7, núm. 4, 2015, pp. 1-4
Instituto de Aeronáutica e Espaço
São Paulo, Brasil

Available in: <http://www.redalyc.org/articulo.oa?id=309442578004>

- How to cite
- Complete issue
- More information about this article
- Journal's homepage in redalyc.org

redalyc.org

Scientific Information System

Network of Scientific Journals from Latin America, the Caribbean, Spain and Portugal
Non-profit academic project, developed under the open access initiative

Thermoelectric-Sourced Programmable Electronic Switching Module to Ignite Electro-Explosive Devices

Aleti Sudheer Babu¹, Kameshwar Kumar Mishra¹, Sudhir Laxman Jawale¹, Prakash Dattatreya Kshirsagar¹, Himanshu Shekhar¹

ABSTRACT: A microcontroller-based programmable electronic switching module is designed and developed. For supplying power to this module, thermoelectric generators (TEGs) are electrically integrated to the switching module. This integrated switching module is carried out to develop a Thermoelectric-sourced Programmable Electronic Switching Module (TPESM), which has many applications in the defence, space and many other fields. This module can also be used to charge batteries and to operate some micro-electronic devices. The main objective of this paper was to use the available heat sources in armament stores for some needful applications. This module was successfully developed and proved to ignite electro-explosive devices (EED) at pre-programmed timing using programmable electronic switching module, which operates by the generated voltage of TEG. This paper discusses the applications, development, operation, experiments and results of this module.

KEYWORDS: Thermoelectric generator, Electro-explosive device, Microcontroller, Electronic switching module.

INTRODUCTION

In a war scenario, the batteries of soldier's electronic devices often discharge due to their continuous usage. This is the critical problem often faced by the soldiers as their electronic devices become non-operational without batteries. A non-conventional type of charging of these batteries using available resources will be a great help to them. Another application of this research is for power supply requirement in armament store. Generally, the armament stores have the huge thermal batteries to operate various electronic devices, as electro-explosive devices (EEDs) of the stores during their operation. For space constraint applications, using these batteries may not be feasible. This developed module solves the above-mentioned problems.

A wide range of EEDs (Danali *et al.* 2010) are used for performing various roles like ignition of rocket propellants, rocket motor stage separation, ignition of gun propellant, ignition of pyrotechnic devices etc. Pyrotechnic delays are designed to safely activate EEDs at a controlled time and in a pre-determined sequence for armament store. Due to some disadvantages of chemical delays, a programmable electronic switching module with high accuracy is required. These electronic devices require specified power supply for their operation as per their circuit design. In this paper, thermoelectric generators (TEGs) are used as power source. TEGs (Rowe and Min 1998) are devices which convert heat (the temperature difference across hot and cold side of TEG) directly to electrical energy, using "seebeck effect". In this study,

¹.Ministry of Defense – High Energy Materials Research Laboratory – Instrumentation Division – Pune – India.

Author for correspondence: Aleti Sudheer Babu | Ministry of Defense – High Energy Materials Research Laboratory | Sutarwadi – 411021 – Instrumentation Division – Pune – India | Email: sudheerbabu_drdo@yahoo.co.in

Received: 07/31/2015 | Accepted: 10/09/2015

TEG is electrically integrated with microcontroller-based programmable electronic switching module for developing Thermoelectric-sourced Programmable Electronic Switching Module (TPESM).

MODULE DEVELOPMENT

In the present paper, the microcontroller- (Make-Microchip, PIC12F629) based programmable electronic delay device is designed and developed to switch on the electronic switch at pre-programmed timing (Babu *et al.* 2013). This switching module is integrated with and powered by TEG (Giuppi *et al.* 2013; Riffat and Ma 2003; Kajikawa 1996) source. This integrated module can be placed on any available heat source in various space and defence applications (Abelson 2005; Goodrich Corporation 2005) in such a way that the hot side of thermoelectric generator will be on the hot surface and cold side of thermoelectric generator at ambient temperature. When TEG is subjected to heat source, the DC voltage equivalent to temperature difference of TEG's hot and cold sides is generated at its output terminals.

In this development, TEG1-12610-5.1 model is used. TEG will generate the voltage as long as the difference in temperature of hot and cold surfaces is maintained. Figure 1 is a schematic diagram of the TPESM. In this design, considering that the temperature difference may not be maintained for long times due to practical reasons, capacitor *C* is used to store the TEG-generated voltage. Once the hot surface of TEG is subjected to heat source, the produced voltage across TEG output will be stored in capacitor *C*. Once the capacitor is charged, microcontroller goes to operation mode, switches

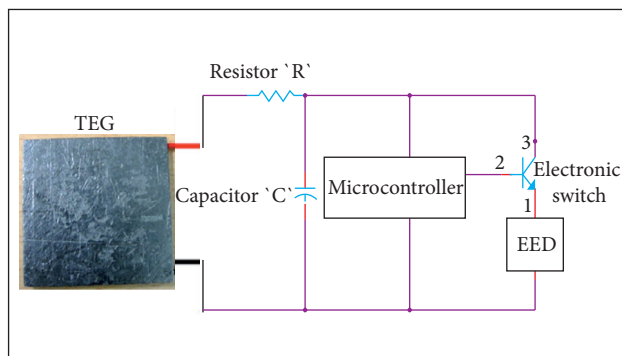

Figure 1. Thermoelectric-sourced programmable electronic switching module.

on the electronic switch at pre-programmed delay timing and ignites the EED connected to it.

OPERATION OF TPESM

- Once the microcontroller of module is programmed for certain timing, it retains the time value in its EEPROM.
- When the module is subjected to heat source, thermoelectric generator produces the output DC voltage equivalent to temperature difference of hot and cold sides of TEG.
- This developed voltage will be stored in the capacitor bank.
- Once the required voltage is developed in capacitor, the microcontroller starts its operation and switches on the electronic switch at a pre-programmed time.
- When the electronic switch is "ON", the capacitor discharges through EED and gets ignited.

EXPERIMENTS AND RESULTS

Initially, to check the performance of TEG1-12610-5.1, experiments are conducted to check the experimental voltage and current levels generated by TEG. In these experiments, we used the load resistance of 10 Ω across TEG output terminals, keeping cold side at ambient temperature of 25 $^{\circ}\text{C}$ and varying hot side temperature. Table 1 shows the voltage and current levels generated by TEG at different hot side temperatures with ambient temperature of 25 $^{\circ}\text{C}$ at the cold side.

Different types of EEDs have different ignition energies. So to use the TPESM for ignition of particular EED, we have to consider the ignition energy *E* of EED and probable temperature difference available across TEG. For the available temperature difference, the developed voltage *V* from Table 1 is considered for calculating the required capacitance *C* of the module using Eq. 1.

$$\text{Energy across capacitor} \quad (1)$$

$$(\text{ignition energy } E) = 1/2 \times C \times V^2$$

For an application, if available temperature difference across TEG could be about 280 $^{\circ}\text{C}$, then, from the experimental data of Table 1, 5.2 V will be generated by TEG. If the EED

to be ignited in the same application requires 25 mJ, then the required capacitance in this module is calculated using Eq. 1, which will be 1,849 μF .

For testing the integrated module TPESM, 25 ms delay (programmed delay) of time is programmed and output of module is connected to an EED, which requires 25 mJ of ignition energy. Here, 2,000 μF (~ 1,849 μF) capacitance is used. When TEG is paced on heating element at 280 °C, as shown in Fig. 2, TEG produced a voltage of about 5 V and, as required, the module ignited the EED at pre-set delay of 25 ms. Both the time at which controller started operating and the time of EED ignition are monitored on oscilloscope (Make-HIOKI) for actual measured delay. For repeatability, TPESMs are programmed with pre-set delay of 25, 50, and 100 ms, and 8 tests for each preset delay are conducted. The summary of tests results is shown in Table 2. The programmed delays shown in Table 2 are the pre-set timings, and measured delays are the values measured

using oscilloscope. It is observed that the accuracy of TPESM functioning is within the accuracy of $\pm 1\%$.

CONCLUSION

This module is used to harness the heat energy using TEG, and the developed voltage can be stored to ignite the EEDs for different operations in defence applications. The feature of this module to function without any live power source (capacitor can be charged and there is no need for continuous power supply) benefits many of the armament applications like grenades, which have to function after a certain delay without any live power source. This means, initially, you may subject this module to heat source (by which capacitor charges) and it may be ejected, and then the module will ignite EED connected to it at a pre-programmed delay. These thermoelectric generators can also be used for charging the military communication devices with available heat sources. Further, this module introduces inbuilt safety in various armament applications, as the power supply will not be supplied to EEDs, until the heat source is available to TPESM. This module is also useful in many other applications in our everyday life, where we can use heat energy being wasted unknowingly. As this technology is proved, a further study on this subject refers to the usage of this technology in defence products and applications.

Table 1. Generated voltage and current levels.

Hot side temperature of TEG (°C)	Generated voltage (V)	Generated current (A)
100	1.8	0.65
150	2.5	1
200	3.7	1.35
250	4.7	1.5
280	5.2	1.7

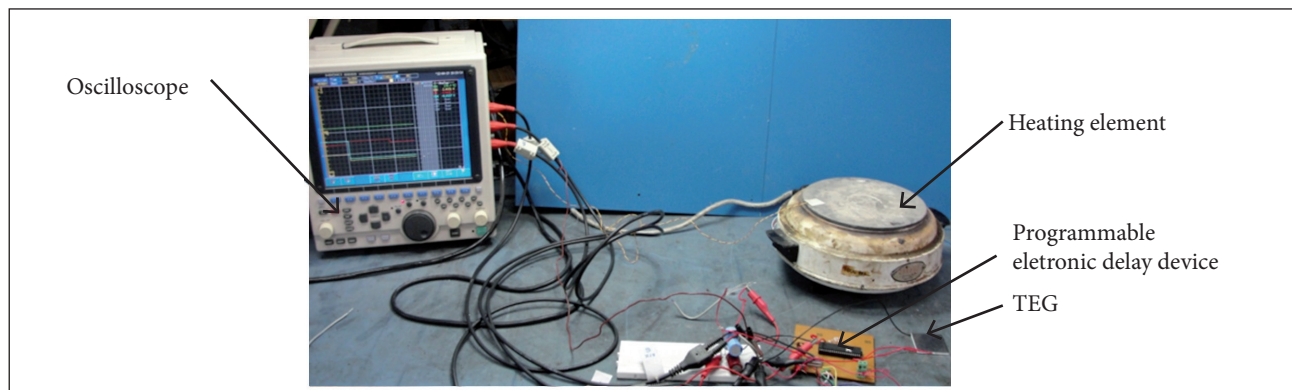

Figure 2. Experimental setup for testing the operation of TPESM.

Table 2. Comparison of programmed and measured delay timings of TPESM functioning.

Programmed delay (ms)	Measured delays (ms)							
	Test 1	Test 2	Test 3	Test 4	Test 5	Test 6	Test 7	Test 8
25	25.0	25.1	25.1	24.9	25.0	25.2	25.0	24.8
50	49.9	49.9	50.3	50.1	49.8	50.1	50.0	50.0
100	100.3	100.7	99.2	99.5	100.5	100.1	100.3	100.5

REFERENCES

Abelson RD (2005) Space missions and applications. In: Rowe DM, editor. Thermoelectrics: macro to nano. Boca Raton: CRC Press.

Babu AS, Mishra KK, Kshirsagar PD, Himanshu S, Rasane VS (2013) Programmable electronic delay device for detonator. Defence Sci J 63(3):305-307. doi: 10.14429/dsj.63.2880

Danali SM, Palaiah RS, Raha KC (2010) Developments in pyrotechnics. Defence Sci J 60(2):152-158. doi: 10.14429/dsj.60.333

Giuppi F, Niotaki K, Collado A, Georgiadis A (2013) Challenges in energy harvesting techniques for autonomous self-powered wireless sensors. Proceedings of the 43rd European Microwave Conference; Nuremberg, Germany.

Goodrich Corporation (2005) Next-generation thermo-electric digital time delay device. Replacement for current pyrotechnic delay cartridges. Aircraft Interior Products, Propulsion Systems.

Kajikawa T (1996) Thermoelectric power generation systems recovering heat from combustible solid waste in Japan. Proceedings of the 15th International Conference on Thermoelectrics; Pasadena, USA.

Riffat SB, Ma X (2003) Thermoelectrics: a review of present and potential applications. Appl Therm Eng 23(8):913-935. doi: 10.1016/S1359-4311(03)00012-7

Rowe DM, Min G (1998) Evaluation of thermoelectric modules for power generation. J Power Sources 73(2):193-198. doi: 10.1016/S0378-7753(97)02801-2